



QUALITY... PLAIN & SIMPLE®

Automatic Electronic Sport Mode Shifter Installation Instructions

General Installation Notes:

Please read these instructions completely before beginning the installation. If you have any questions, please call.

Before beginning the installation, disconnect the negative battery cable and use wheel chocks to block the vehicle's wheels.

Make sure the engine, transmission, body and frame are properly grounded.

Refer to Fig. 1 for the component names.

Tools and Materials Required:

- Standard Allen wrenches: 1/8", 5/32", 3/16"
- Wrench or Socket Sizes: 3/8", 7/16", 1/2", 9/16", 7/8", 15/16", 10mm, 15mm
- Tape Measure
- Metal cutting tool, such as a hacksaw or a die grinder with a cut-off wheel
- Drill and 5/16" drill bit
- Ohmmeter
- Wire cutters/strippers
- Wire crimping or soldering tools

Lokar Shifters are designed to fit specific transmissions. Before installing the Shifter, verify that you have the proper model for your transmission. If your Shifter does not seem to connect to the transmission properly, do not make modifications during installation as this may void your warranty. Call for assistance.

The shifter mounting brackets can be installed several different ways: on the bottom facing down; on the top facing up; or facing vertical surfaces on the front and back of the shifter mechanism. They are installed on the bottom from the factory. This position will usually be best if the shifter will be mounted directly to the floor or transmission tunnel. If you are installing the shifter in a console, you may wish to relocate the mounting brackets to the top or to the front and back.

Verify that the shifter length you have purchased is what you actually want. When installed with the mounting brackets on the bottom of the shifter mechanism, the bottom of the shifter lever will be approximately 4-1/2" above the bottom of the mounting brackets. From that point up to the top of the knob is how the shifter length is determined. If you relocate the mounting brackets to the top of the shifter mechanism, the bottom of the shifter lever will be approximately 1/2" above the top of the mounting brackets.

The Shifter must be installed into the vehicle before attempting to make any adjustments.

The shifter lever is designed to lock in Park and in Neutral. You must depress the release button in the top of the shifter knob in order to shift out of Park or Neutral.

Automatic Electronic Sport Mode Shifter Installation Instructions

Building American Quality... With A Lifetime Warranty!®

TOLL FREE 1-877-469-7440 • tech@lokar.com • www.lokar.com

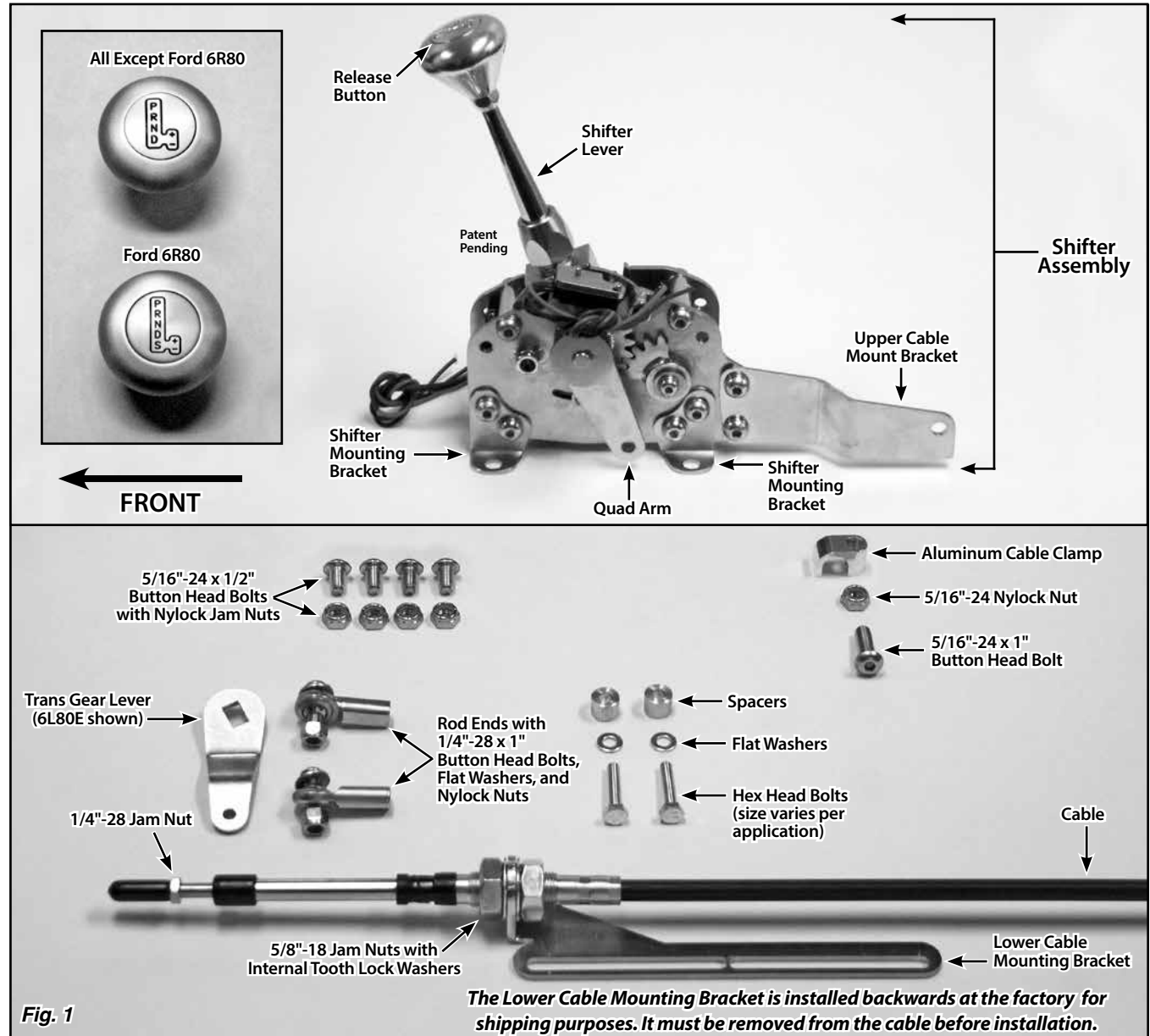
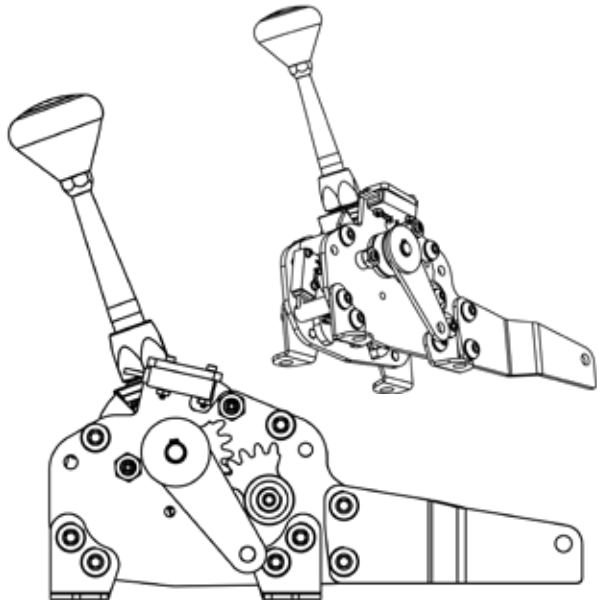

Fig. 1

The Lower Cable Mounting Bracket is installed backwards at the factory for shipping purposes. It must be removed from the cable before installation.

Shifter Mounting Bracket Options

Bottom Mount



Fore-Aft Bottom Mount

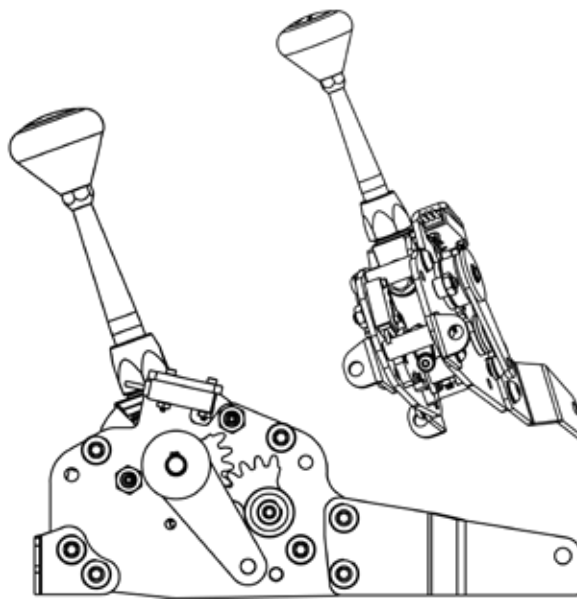

Fore Mount

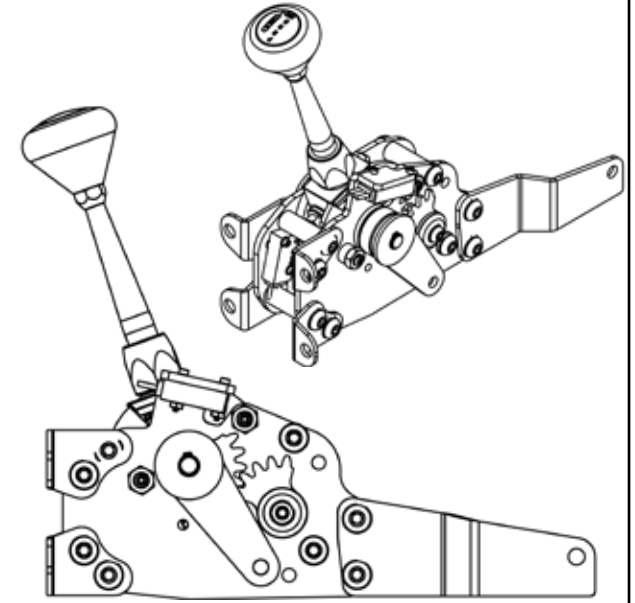

Top Mount

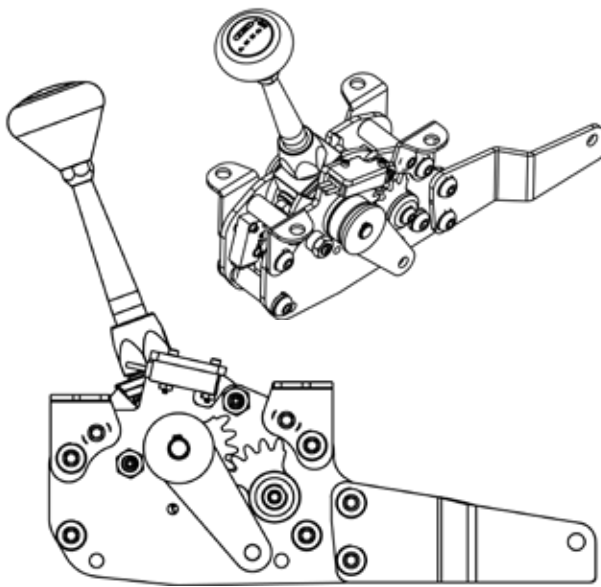

Fore-Aft Top Mount

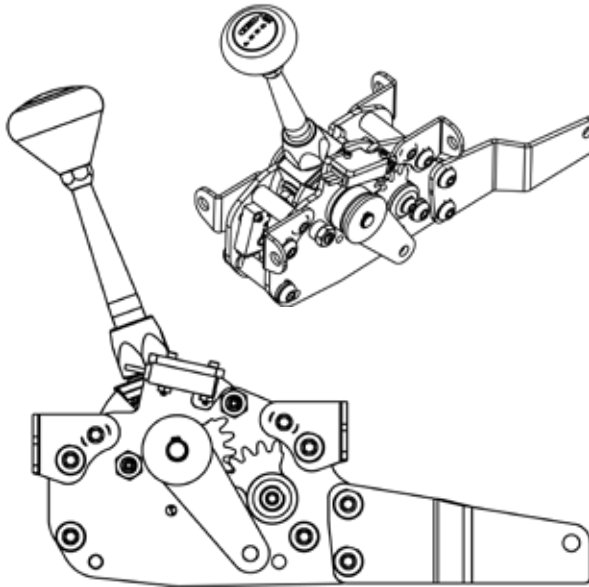

Aft Mount

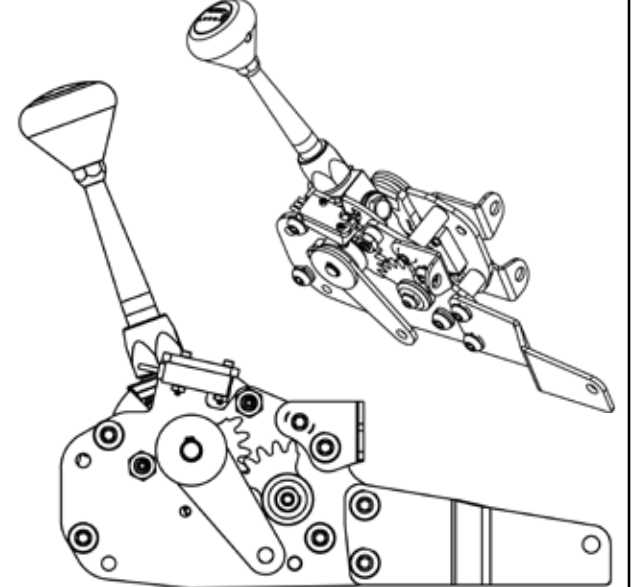

Fig. 2

All EXCEPT Ford 6R80: To shift from Park directly to Drive (or Overdrive, depending on the transmission), depress the release button and hold it down while moving the shifter lever, and the shifter lever will stop in the Drive (or Overdrive) position. To engage Manual mode, push the shifter lever to the passenger side while in the Drive (or Overdrive) position. The shifter lever can then be "bumped" forward or backward to shift up or down. Push the lever back to the driver side to exit Manual mode.

Ford 6R80: Depress the release button and hold it down while moving the shifter lever, and the shifter lever will stop in the Sport mode position. To engage Manual mode, push the shifter lever to the passenger side from Sport mode. The shifter lever can then be "bumped" forward or backward to shift up or down. Push the lever to the driver side to exit Manual mode. To engage regular Drive mode, push the lever forward one notch from Sport mode (this detent is provided by the transmission, and is not a separate detent in the shifter). **NOTE:** The lever can only be moved to the Manual mode position from the Sport mode position, not from Drive.

The Lokar Electronic Sport Mode Shifter is designed and intended to be used with an aftermarket Transmission Control Unit (TCU). You will need to follow the instructions for your particular TCU in order to connect the shifter wiring. The Lokar Electronic Sport Mode Shifter may also be used with a factory Powertrain Control Module (PCM), but there are too many different combinations and too many variables for these instructions to cover those possibilities. If you are going to use the Lokar Electronic Sport Mode Shifter with a factory PCM, you will likely need aftermarket tuning software to create a custom program for the PCM, and you will need to create a custom wiring harness to connect the Shifter to your PCM.

Ford AODE and 4R70W Only: These two transmissions require the installation of a Lokar Selector Shaft and Trans Arm Kit (included). The Selector Shaft and Trans Arm Kit can be installed with the transmission in the vehicle on most applications. However, if the transmission is already removed from the vehicle, it is easier to install the Selector Shaft and Trans Arm Kit while the transmission is removed. **These installation instructions assume that you have completed the installation of the new Selector Shaft and Trans Arm Kit before you begin the Shifter installation.** **NOTE:** The "trans arm" on the AODE and 4R70W is equivalent to the "trans gear lever" in these instructions.

Step 1: If your vehicle already has a shifter of any type installed, disconnect all shifter linkage and remove the shifter and its related hardware (neutral safety switch, back-up light switch, etc.).

Step 2: Determine exactly where you want the Shifter to be located. The Shifter may be mounted either on top of the transmission tunnel or floor, or inside a console or dashboard. It **MUST** be mounted inside the passenger compartment and away from the weather.

Step 3: As mentioned earlier, the shifter mounting brackets are installed at the factory on the bottom of the shifter. If you wish to mount the shifter to the underside of a console or in the dashboard, you can reposition the brackets as needed. Remove both brackets from one side of the shifter assembly. **DO NOT REMOVE ALL FOUR BRACKETS AT THE SAME TIME!** There are several different mounting possibilities for the brackets. **Fig. 2** Position them how you want and reinstall the bolts, making sure that the longer bolts go into the threaded spacers that hold the shifter together.

Once you have one side completely back together and all four bolts tight, follow the same procedure to reposition the brackets on the other side.

Step 4: Place the Shifter in the desired location. Make sure the shifter lever will not interfere with the dash when in Park, or with the seat when in Drive.

NOTE: If you find after installation that the shape or length of the shifter lever is not suitable for your application, Lokar has a number of different styles and lengths of Shifter Lever Conversion Kits available for purchase separately through our dealer network.

Step 5: There will need to be an opening in the floor for the shifter cable to pass through. Determine where the best spot would be, keeping in mind that the straighter the cable is, the more smoothly the Shifter will operate. The shifter cable should be protected by a grommet (not included) where it passes through the transmission tunnel or floor.

Cut any necessary openings now.

Step 6: Loosen the button head bolts that attach the shifter mounting brackets to the shifter, just enough so that the brackets can slide if needed. Place the shifter assembly in position on the vehicle. Make sure the shifter mounting brackets are sitting flush on the surface they will be bolted to. Mark the center of the bolt holes in the shifter mounting brackets. Center punch the marks, and drill 5/16" diameter holes.

Step 7: Attach the shifter mounting brackets to the vehicle using four 5/16"-24 x 1/2" button head bolts and nylock jam nuts. Once the shifter assembly is mounted, tighten the bolts that attach the shifter mounting brackets to the shifter.

Step 8: Make sure the transmission is in Park by rotating the original trans gear lever clockwise as far as it will go.

All EXCEPT Ford AODE & 4R70W: Remove the original trans gear lever from the transmission selector shaft. Install the new trans gear lever onto the selector shaft, pointed down and towards the front. Re-use the original nut to secure the trans gear lever.

Step 9: Remove the lower cable mounting bracket from the cable. Install the lower cable mounting bracket on the driver side of the transmission pan, with the cable mounting hole towards the rear of the transmission, using the provided hex head bolts, flat washers, and spacers. On some transmissions, the cable mounting hole is on the top side of the bracket, and on others it is on the bottom side of the bracket. **NOTE:** If the transmission has an aluminum pan, the spacers may not be necessary.

Step 10: Make sure that the shifter lever and the transmission are both in the Park position. Install the cable into the lower cable mounting bracket, and then, reinstall the lock washer and jam nut onto the cable.

Step 11: Feed the other end of the cable up through the opening in the transmission tunnel or floor. When routing the cable, make sure that it is not touching the exhaust or any moving parts. The cable should be routed as smoothly as possible without any sharp bends.

Step 12: Make sure that the 1/4"-28 jam nuts are installed on each end of the cable. Then, install the rod ends onto the cable, threading them on approximately halfway. Do not tighten the jam nuts against the rod ends yet.

Step 13: The inner cable needs to be fully extended all the way out at the transmission end when it is attached to the trans gear lever. Pull the inner cable out as far as it will go. Determine if the rod end needs to be installed on the inside or the outside of the trans gear lever, in order for the cable to be as straight as possible.

Adjust the position of the lower cable mounting bracket, the position of the cable itself in the bracket, and/or the rod end so that the hole in the rod end lines up with the hole in the trans gear lever with the inner cable fully extended and the transmission in Park. Attach the rod end at the transmission to the trans gear lever. **Figs. 3, 4, 5, 6, and 7.** Make sure that the rod end is sandwiched between the trans gear lever and the flat washer. **Fig. 8**

NOTE: 4L60E transmissions ONLY: Install the 1/8" spacer (provided) between the rod end and the trans gear lever. **Fig. 9**

Once the rod end is attached to the trans gear lever, tighten the lower cable mounting bracket bolts.

Step 14: Attach the other rod end to the quad arm on the Shifter using a 1/4"-28 x 1" button head bolt, flat washer, and nylock nut. **Fig. 10** Make sure the rod end is sandwiched between the quad arm and the flat washer.

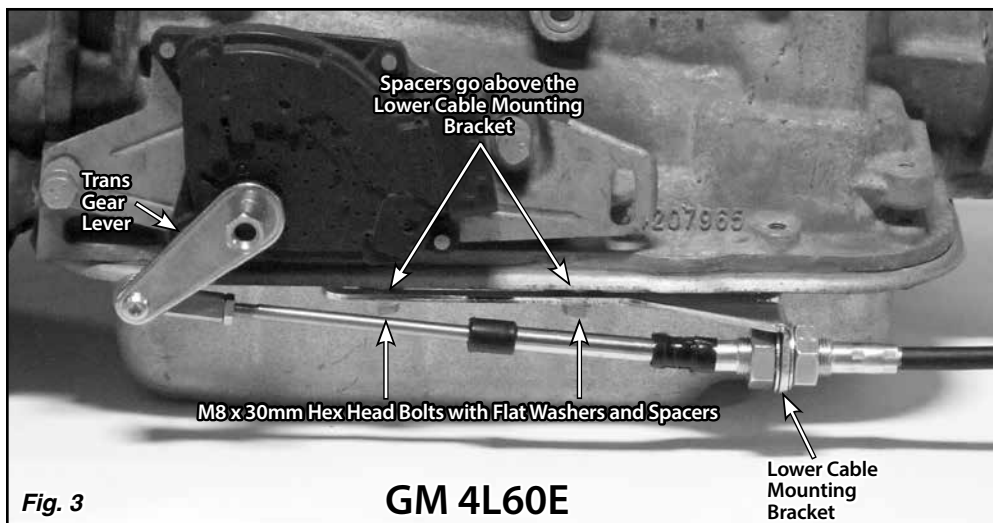

Fig. 3

GM 4L60E

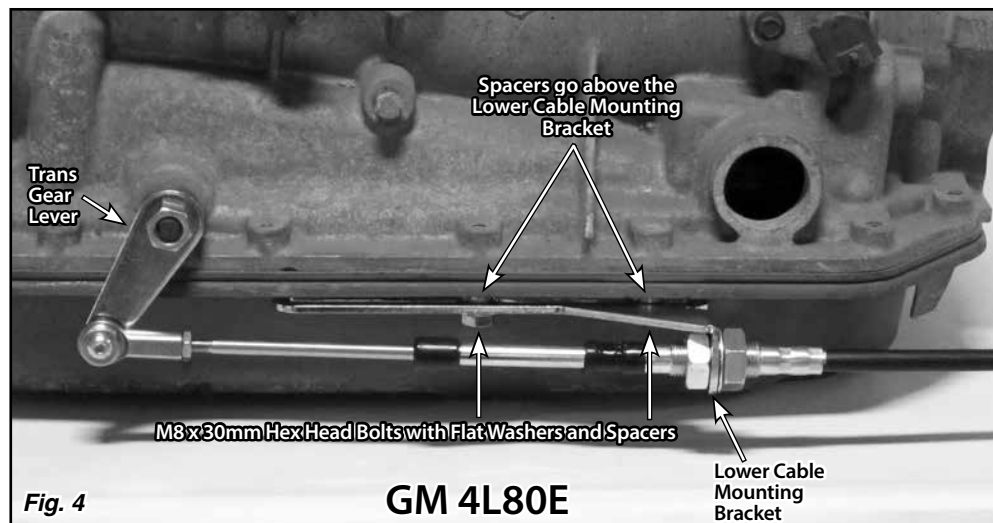

Fig. 4

GM 4L80E

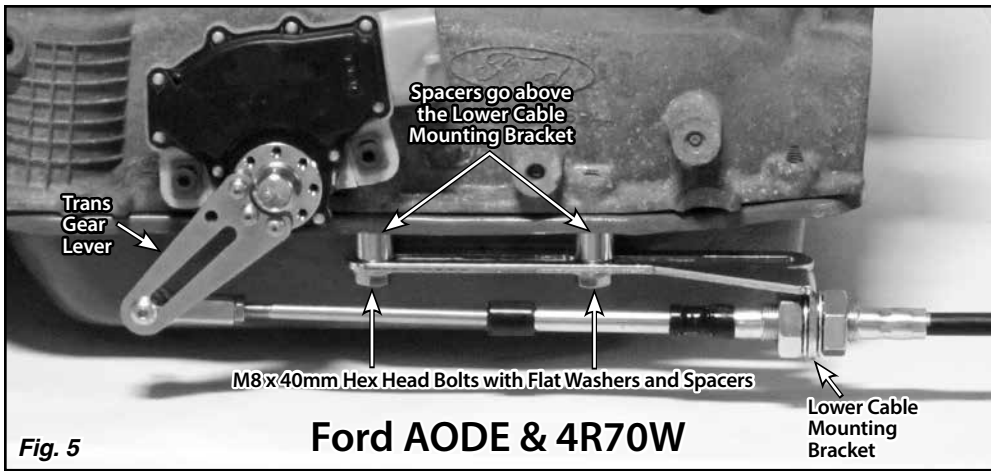

Fig. 5

Ford AODE & 4R70W



Fig. 6

GM 6L80E & 6L90E

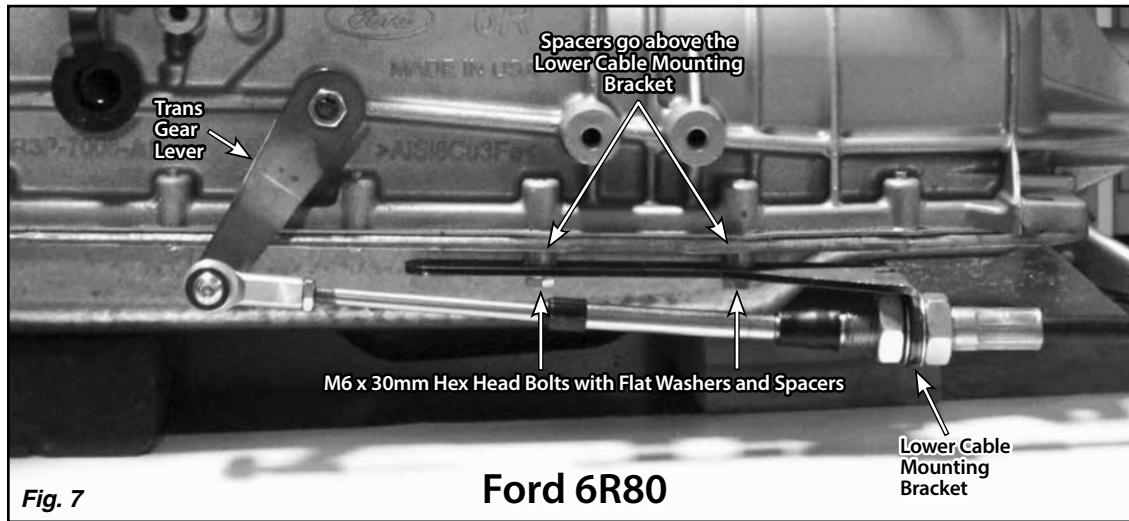

Fig. 7

Ford 6R80

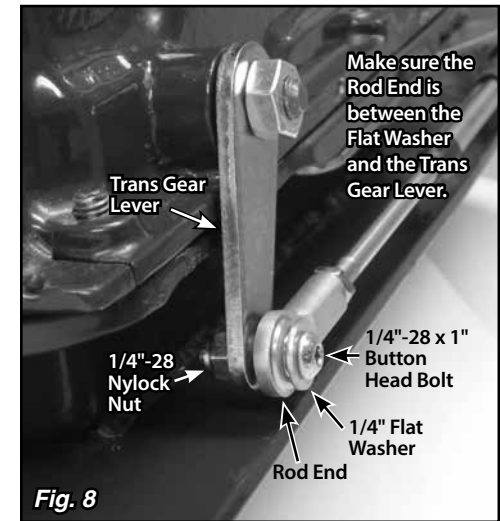

Fig. 8

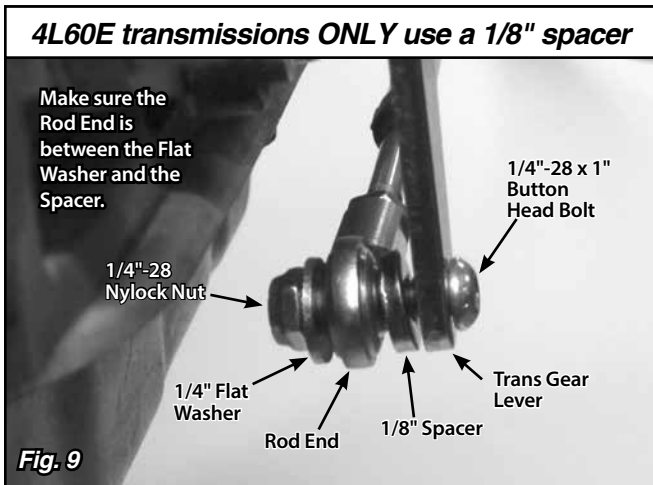

Fig. 9

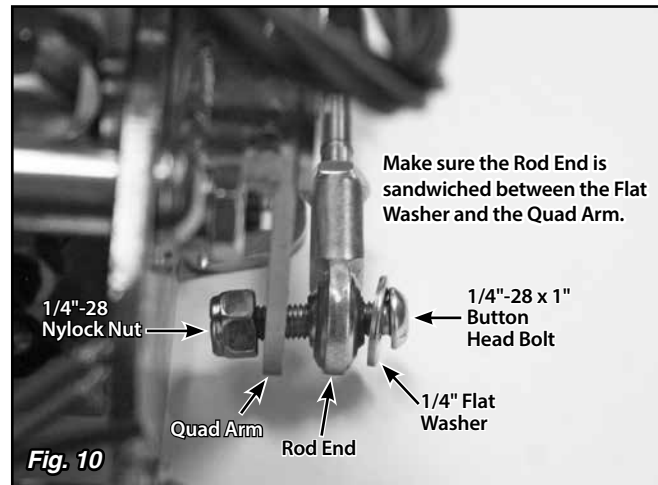

Fig. 10

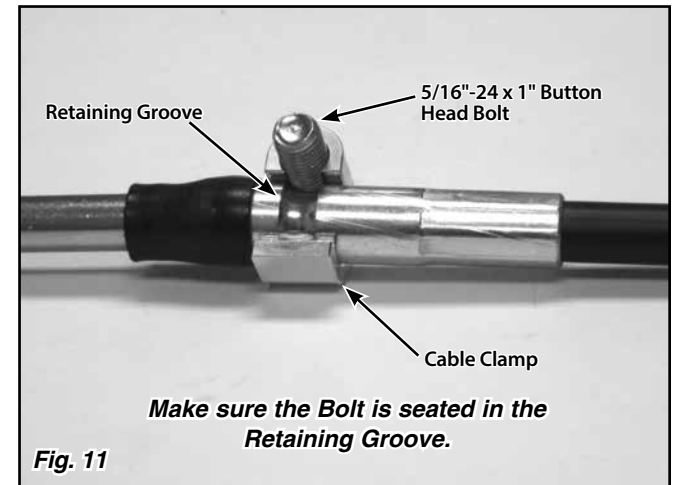

Fig. 11

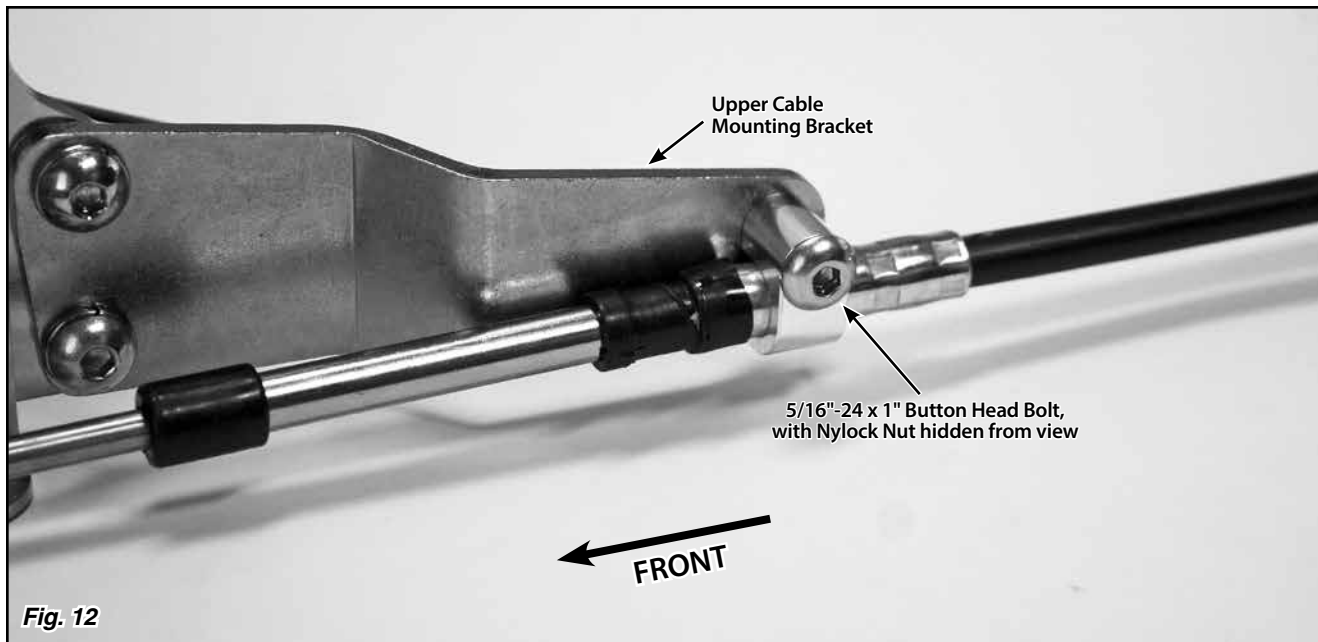

Fig. 12

Step 15: Insert the 5/16"-24 x 1" button head bolt into the upper cable clamp, and position the upper cable clamp on the cable, making sure that the bolt is seated in the retaining groove. **Fig. 11**

Install the upper cable clamp and 5/16"-24 x 1" button head bolt onto the upper cable mounting bracket and secure with a nylock nut. **Fig. 12**

Step 16: Check the adjustment of the shifter cable by placing the shifter lever all the way forward into the Park position. Make sure that the release button still moves up and down freely. The release button should be flush with the knob in Park and Neutral. In the Reverse position, you cannot pull the lever back into Neutral without depressing the release button.

While the shifter lever is in the Park position, make sure the transmission is firmly in the Park detent, with no tension on the cable. You can verify that there is no tension on the cable by removing the 1/4"-28 x 1" bolt with nylock nut that attaches the rod end to the quad arm or trans gear lever at either end of the cable. Make sure the hole in the rod end exactly aligns with the hole in the quad arm or trans gear lever. The bolt should pass freely through both holes at the same time without binding. Do not force the holes to line up.

If the holes are not aligned, use the 5/8"-18 jam nuts at the lower cable mounting bracket to get the adjustment close. Then, you can fine-tune it by adjusting the rod ends until you can slide the bolt in and out without putting tension on the cable. Make sure that the quad arm and trans gear lever do not move during the adjustment procedure. Also, make sure that the inner cable is still fully extended at the transmission end.

Use this adjustment routine until the bolts will pass freely in and out of both of the rod ends and the quad arm and trans gear lever. Reinstall the 1/4"-28 nylock nuts and the flat washers onto the bolts and tighten.

Once you have the shifter cable adjusted correctly, tighten the 1/4"-28 jam nuts on the ends of the cable, and the 5/8"-18 jam nuts at the lower cable mounting bracket.

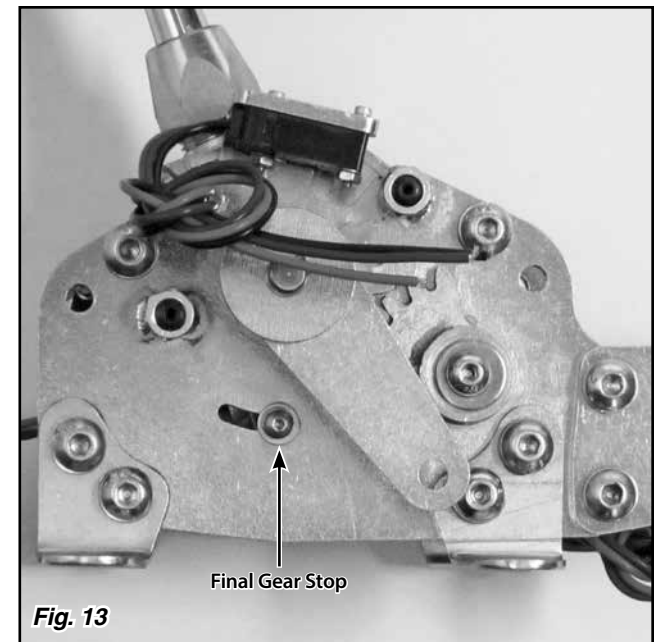

Fig. 13

Final Gear Stop Adjustment (optional, if desired, except Ford 6R80 see special section below)

The lowest gear position the shifter lever is able to physically reach can be adjusted by moving the final gear stop. The final gear stop is set from the factory so that the highest transmission gear position (Drive or Overdrive, depending on the transmission) is the only forward position that can be reached (except Ford 6R80). This is the position that allows the lever to be moved toward the passenger side, into Manual mode (except Ford 6R80).

Some transmission controllers offer features that allow for extra functionality when the trans gear lever is in lower gear positions. By adjusting the final gear stop on the Lokar Shifter, you can gain access to this functionality if desired. You will also be able to provide physical, manual gear selection if that option is available with your transmission and controller.

To adjust the final gear stop to allow for additional lower gear positions, loosen the final gear stop with a 3/32" Allen wrench and an 11/32" open-end wrench. Move the shifter lever to the lowest gear position you want to be available. Slide the final gear stop rearward as far as it will go with the shifter lever in that position, and tighten the final gear stop.

NOTE: The Shifter cannot be moved over into the Manual mode from any of the lower gear positions (except Ford 6R80). The shifter lever must be in the Drive (or Overdrive) position in order to be moved over into Manual mode (except Ford 6R80).

To set the final gear stop back to the factory default setting, loosen the final gear stop with a 3/32" Allen wrench and an 11/32" open-end wrench. Then, move the shifter to the Drive (or Overdrive) position, and move the lever toward the passenger side into Manual Mode. Slide the final gear stop rearward as far as it will go, and tighten.

Ford 6R80 Only:

The final gear stop on the Ford 6R80 shifter is set from the factory so that the shifter already has an additional forward gear position (Sport, in addition to Drive). On the Ford 6R80 shifter **ONLY**, the lever cannot be moved to the passenger side into Manual mode from Drive. The lever must be moved all the way back to the Sport position in order to be able to move the shifter lever to the passenger side into Manual Mode.

Wiring the Manual Mode and Bump-Shift Switches

The Lokar Electronic Sport Mode Shifter can function just like a traditional automatic transmission shifter if you wish. It is not necessary to even connect the wiring for the Manual mode switches if you do not want the "bump-shift" functionality.

There are three identical switches on the Sport Mode Shifter, **Fig. 14** and **Fig. 15** The switches are single pole double throw (SPDT) momentary switches. However, the Manual mode on-off switch is being used as a "latching" (instead of momentary) switch in this application.

Each switch has black, blue, and red wires. The red wire is connected to the normally closed (NC) terminal. The blue wire is connected to the normally open (NO) terminal. The black wire is connected to the common (COM) terminal.

The Manual mode on-off switch is top-center on the driver side of the Shifter base. The Manual mode on-off switch has continuity between the black and the blue wires when the Shifter is in the Drive (or Overdrive) position (**EXCEPT** Ford 6R80, when the lever is in the rearmost Sport position).

Manual mode is activated by pushing the shifter lever to the passenger side when the Shifter is in the Drive (or Overdrive) position (**EXCEPT** Ford 6R80, when the lever is in the rearmost Sport position). The Manual mode switch will then provide continuity between the black wire and the red wire. Pushing the lever back to the driver side turns Manual mode off.

The downshift switch is at the front of the Shifter, and it is activated by pulling the shift lever rearward and releasing it when in Manual mode. At rest, the switch provides continuity between the black wire and the red wire. Activating the downshift switch provides momentary continuity between the black wire and the blue wire, signaling the transmission controller to command a downshift.

The upshift switch is at the rear of the Shifter, and it is activated by pushing the shift lever forward and releasing it when in Manual mode. At rest, the switch provides continuity between the black wire and the red wire. Activating the upshift switch provides momentary continuity between the black wire and the blue wire, signaling the transmission controller to command an upshift.

Please note that with a fully electronic transmission, the shifter only sends a request to the transmission controller to perform a specific task. The response to a shift request may not be immediate, or in some situations may not happen at all, depending on the vehicle speed, engine load or RPM, and how the controller is programmed.

Manual Mode and Bump-Shift Switches

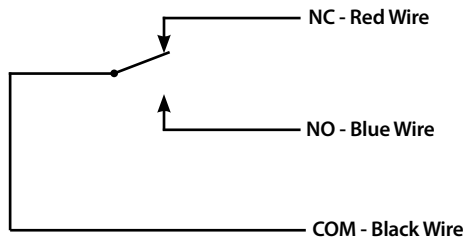

Fig. 14

Neutral Safety Switch Wiring

If your transmission controller has a neutral safety switch output, you may use that output instead of the neutral safety switch on the Shifter.

Step 17: For the neutral safety switch to function properly, the shifter linkage must be adjusted correctly.

The Lokar Neutral Safety Switch is a simple on/off, non-directional switch. The switch passes current (turns on) when the shifter is in the Park or Neutral position.

Test for continuity by connecting an ohmmeter lead to each stud on the neutral safety switch. When the shifter linkage is adjusted correctly, you will only have continuity between the two switch studs when the shifter lever is in Park or Neutral. Continuity in any other gear requires readjustment of the shifter linkage.

Step 18: Connect the neutral safety switch between your ignition switch and starter circuits. Check the wiring of your fuse panel:

- If there are (2) connections for a neutral safety switch, run a #12 (or heavier) stranded wire from these terminals in your fuse panel to the (2) terminals on the neutral safety switch. That completes the Neutral Safety Switch wiring.

- If your fuse panel does not have neutral safety switch connections, locate the wire going from the ignition switch to the starter. If GM color codes are used, this wire will usually be purple. After locating the wire, disconnect it from the starter. It must be cut and routed from the ignition switch to one of the neutral safety switch terminals, and from the other neutral safety switch terminal to the same stud on the starter where the original wire was removed. If the wire must be lengthened, be sure to use wire that is at least the same size or larger than the original.

Step 19: Reconnect the negative battery cable and check operation. Make sure that the engine will not start in Reverse or any forward gear. If it does, follow the shifter linkage adjustment procedure again. If your vehicle should ever start in any gear other than Park or Neutral, please readjust the shifter linkage accordingly. Tighten all brackets and bolts correctly and securely and there should be no movement or maladjustment. If you have any questions after following this procedure, please call Lokar Technical Support.

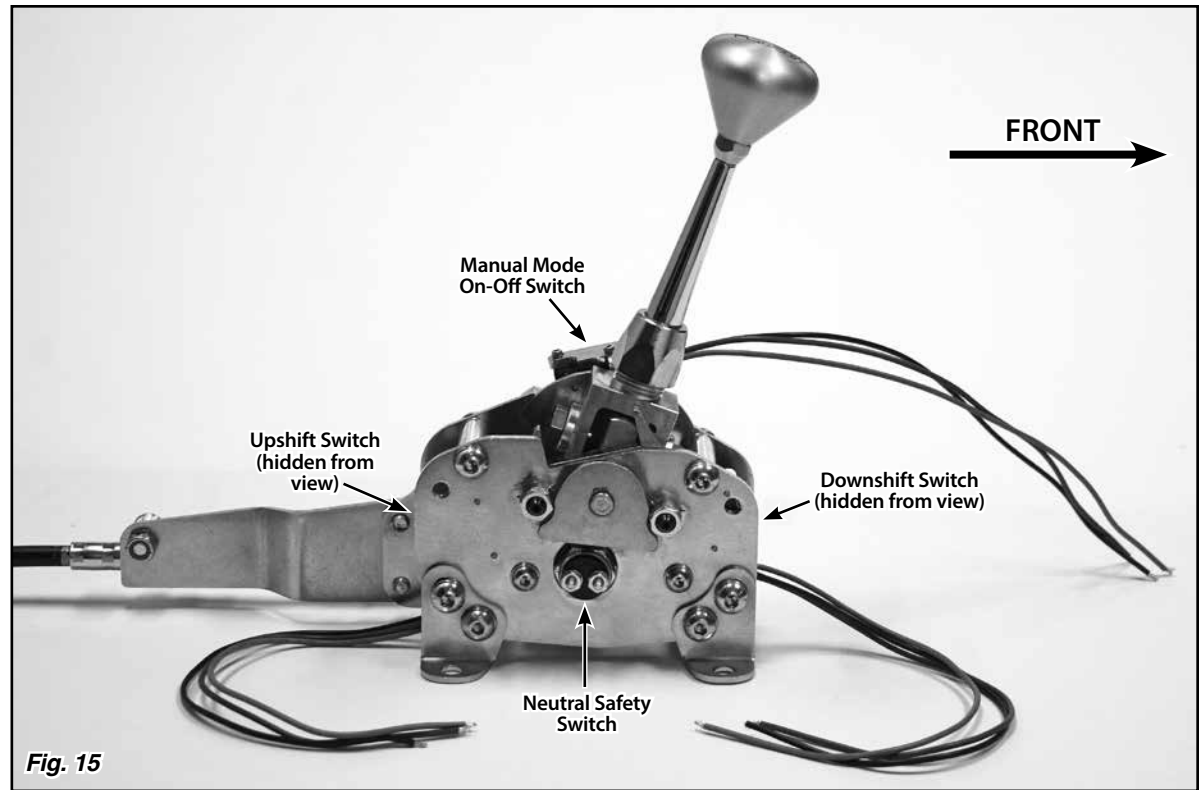

Fig. 15

Lokar Shifter Knob Removal Instructions

To Remove the Shifter Knob:

Step 1: Make sure the shifter lever is all the way forward in the Park position.

Step 2: Loosen the jam nut below the shifter knob. **DO NOT** loosen or remove the set screw that is in the knob. Fig. 16

Step 3: Turn the shifter knob counter-clockwise to remove.

To Install the Shifter Knob:

Step 1: Make sure the jam nut is still in place on the shifter lever.

Step 2: Thread the shifter knob onto the shifter lever until the release button comes up flush with the top of the shifter knob.

Step 3: Tighten the jam nut up against the bottom of the shifter knob.

Step 4: Check to make sure that depressing the release button allows the shifter lever to be moved, and that the shifter lever still locks in Park and Neutral. If the shifter lever will not come out of Park with the release button fully depressed, tighten the knob one turn and check it again. If the shifter lever does not lock in Park, loosen the knob one turn and check it again.

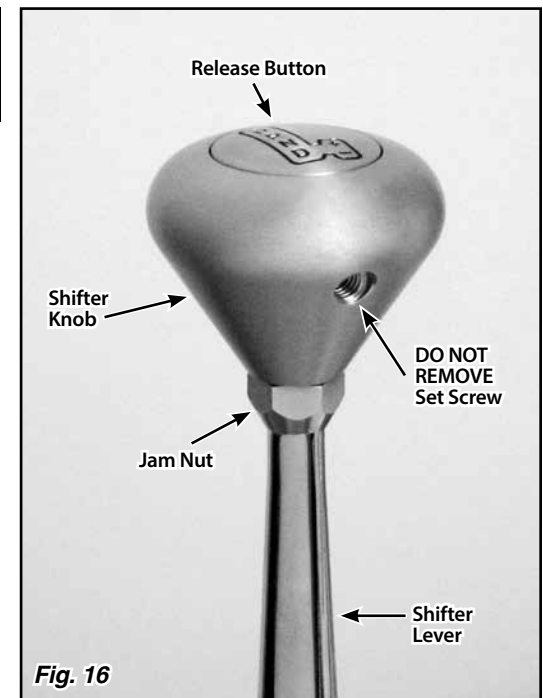

Fig. 16