



QUALITY... PLAIN & SIMPLE®

## AxiShift Bolt-on Shift Lever Adapter Installation Instructions

### General Installation Notes:

Please read these instructions completely before beginning the installation. If you have any questions, please call.

Before beginning the installation, disconnect the negative battery cable and use wheel chocks to block the vehicle's wheels.

Make sure the engine, transmission, body and frame are properly grounded. We recommend using anti-seize lubricant on all aluminum threads.

Refer to Fig. 1 & Fig. 2 for the components.

**Step 1:** Turn the AxiShift Bolt-on Shift Lever Adapter upside down. Use a 3/32" Allen wrench to back out all four of the #10-32 set screws far enough that they are no longer protruding into the center cavity at all. **Fig. 3 & Fig. 4**

**Step 2:** The AxiShift Bolt-On Shift Lever Adapter can be installed to move the shifter lever to the front or to the rear. Determine which direction you want to move the shifter lever.

**Step 3:** If applicable, remove any existing shifter lever or the original Tremec button head bolts and lock washers from the Tremec shifter stub lever on the transmission.

**Step 4:** If you do not have both the original Tremec button head bolts and lock washers AND the 3/8"-24 bolts and lock washers that came with your shifter lever, you will need to obtain a total of four 3/8"-24 x 7/8" (or longer) bolts and lock washers.

Place the AxiShift Bolt-on Shift Lever Adapter against the Tremec shifter stub lever in the position you want. Install and tighten the 3/8"-24 bolts and lock washers. **Fig. 5**

**Step 5:** Install your shifter lever onto the AxiShift Bolt-on Shift Lever Adapter using the two remaining 3/8"-24 bolts and lock washers. **Fig. 6**

**Step 6:** Use a 5/32" Allen wrench to loosen the four #10-32 x 1-1/4" socket head machine screws just enough to be able to move the shifter lever to the position you want it in, but not loose enough that the lever will move when you let it go. **Fig. 7**

# AxiShift™ Bolt-on Shift Lever Adapter (Patent Pending) Installation Instructions

Building American Quality... With A Lifetime Warranty!®

TOLL FREE 1-877-469-7440 • tech@lokar.com • www.lokar.com

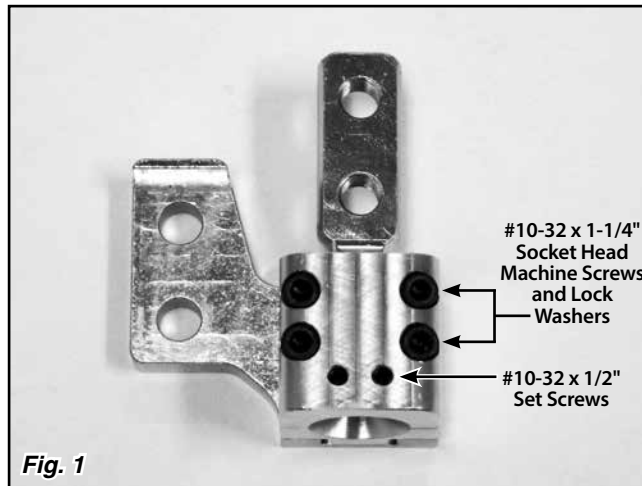

Fig. 1

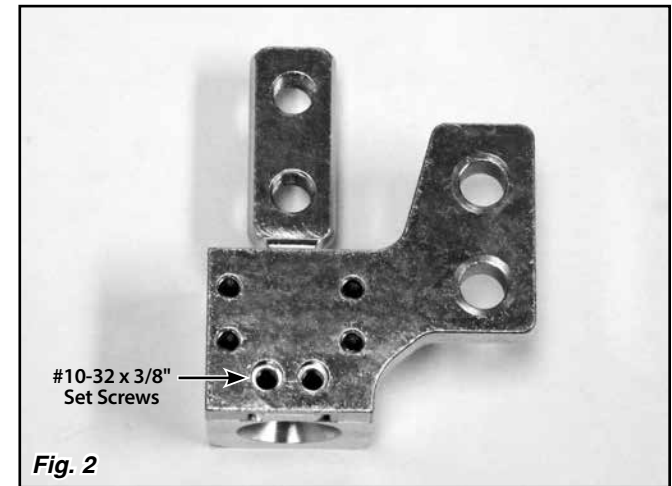

Fig. 2

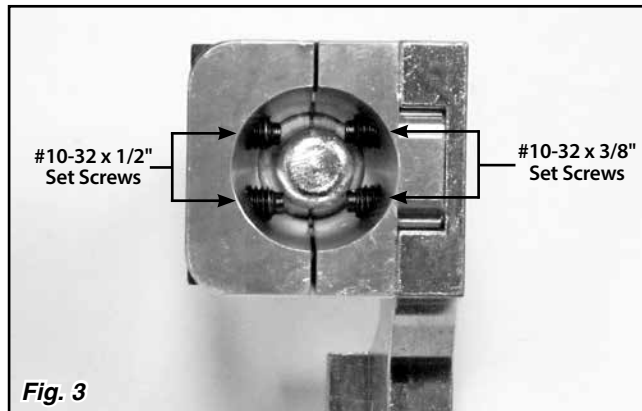

Fig. 3

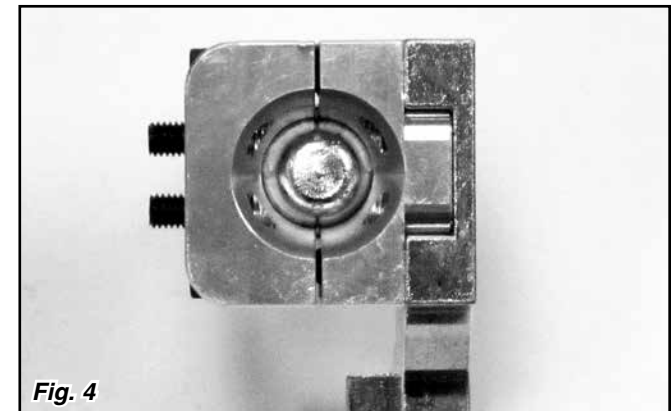

Fig. 4

**Step 7:** Once you have the shifter lever positioned the way you want it, use a 5/32" Allen wrench to tighten the #10-32 x 1-1/4" socket head machine screws. **Fig. 8**

**Step 8:** Gently test shift the transmission into all gears, including reverse, to make sure that there isn't any interference with the dash or seats. If there is any interference, loosen the four #10-32 x 1-1/4" socket head machine screws and adjust as needed. Then, retighten and test shift the transmission again.

**Step 9:** Once the vertical angle and rotation of the shifter lever is finalized, use a 3/32" Allen wrench to tighten the four #10-32 set screws. **Fig. 9 & Fig. 10**

**Step 10:** Test shift the transmission into all gears again to make sure that there isn't any interference with the dash or seats.

# AxiShift Bolt-On Shift Lever Adapter Installation Instructions

