

**Chrysler 727,
904, and 518
Gated Automatic
Transmission
Shifter Installation
Instructions**



Chrysler 727, 904, and 518 Gated Automatic Transmission Shifter Installation Instructions

Building American Quality... With A Lifetime Warranty!

TOLL FREE 1-877-469-7440 • tech@lokar.com • www.lokar.com

General Installation Notes:

Please read these instructions completely before beginning the installation. If you have any questions, please call.

Before beginning the installation, disconnect the negative battery cable and use wheel chocks to block the vehicle's wheels.

Make sure the engine, transmission, body and frame are properly grounded. We recommend using anti-seize lubricant on all aluminum threads.

Refer to Fig. 1 for the component names.

Tools and Materials Required:

- Standard Allen wrenches: 1/8", 5/32", 3/16"
- Wrench or Socket Sizes: 3/8", 7/16", 1/2", 9/16", 7/8", 15/16",
- Tape Measure
- Metal cutting tool, such as a hacksaw or a die grinder with a cut-off wheel
- Drill and 5/16" drill bit
- Ohmmeter
- Wire cutters/strippers
- Wire crimping or soldering tools
- Blue thread locking compound

This Clayton Machine Works Shifter is designed to work with a specific transmission model. Before installation, verify that you have the proper Shifter for your transmission. If your Shifter does not seem to connect to the transmission properly, do not make modifications during installation as this may void your warranty. Call for assistance.

The Clayton Machine Works Shifter is designed to be installed to the rear of the transmission selector shaft.

The Shifter must be installed into the vehicle before attempting to make any adjustments.

This Shifter is offered either with a pre-installed round tubular Shifter Lever, or with a stub designed to accept a Tremec style bolt on Shifter Lever (as pictured in these instructions, Shifter Lever available separately but not included). The installation of both styles of Shifter is the same.

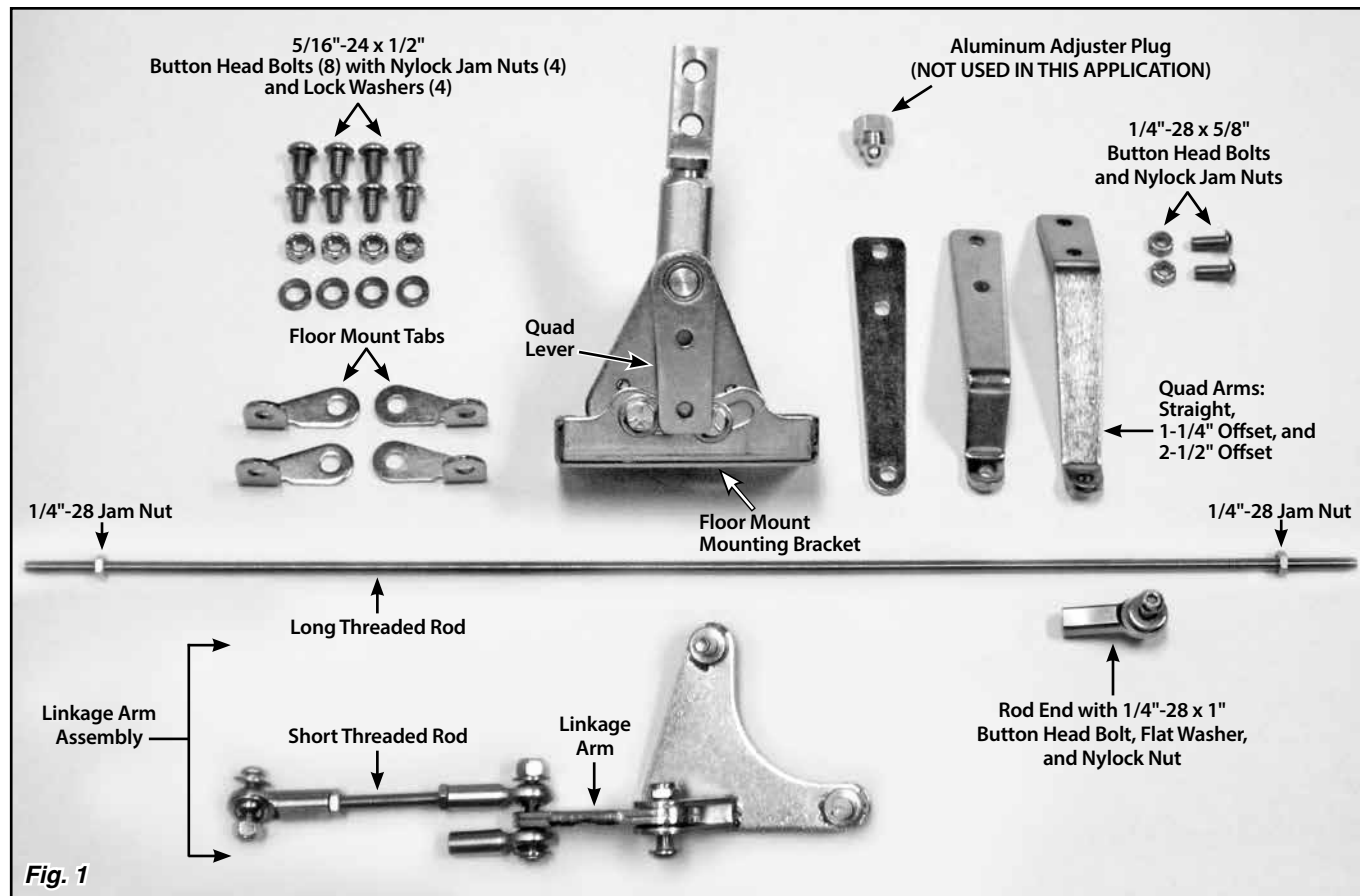

Fig. 1

To move the Shifter out of Park, pull the Shifter Lever towards the driver side, and then pull the Shifter Lever rearward into Reverse. Pull the Shifter Lever rearward again to go into Neutral. Let go of the Shifter Lever, and it will spring back towards the passenger side. The Shifter Lever can then be pulled rearward again into Drive. To access the lower gears, move the Shifter Lever towards the driver side again, and pull rearward.

Step 1: If your vehicle already has a shifter of any type installed, disconnect all shifter linkage and remove the shifter and its related hardware (neutral safety switch, back-up light switch, etc.).

Step 2: Determine exactly where you want the Shifter to be located. The Shifter may be mounted either on top of the floor or underneath the floor.

NOTE: For vehicles that had a floor shifter previously, determine if the existing hole(s) in the floor will be adequate for mounting and operating the Clayton Machine Works Shifter. If not, the floor will need to be modified.

If you are mounting the Shifter on top of the floor, you will need a slot in the floor for the quad arm to pass through. If you are mounting the Shifter underneath the floor, the opening will need to be large enough for the floor mount mounting bracket also.

(continued on Page 2)

Above Floor Installation

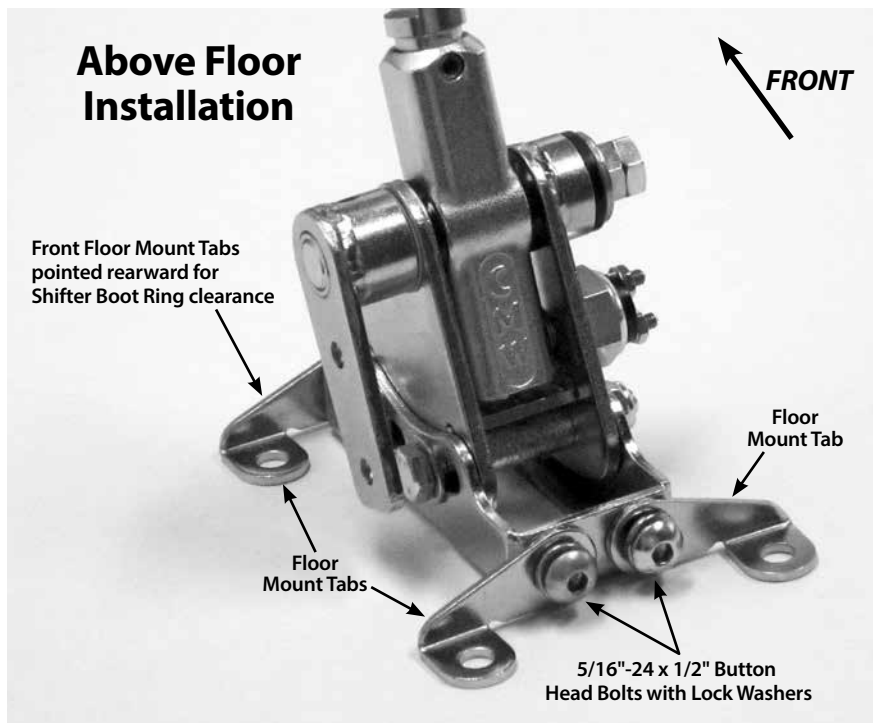

Below Floor Installation

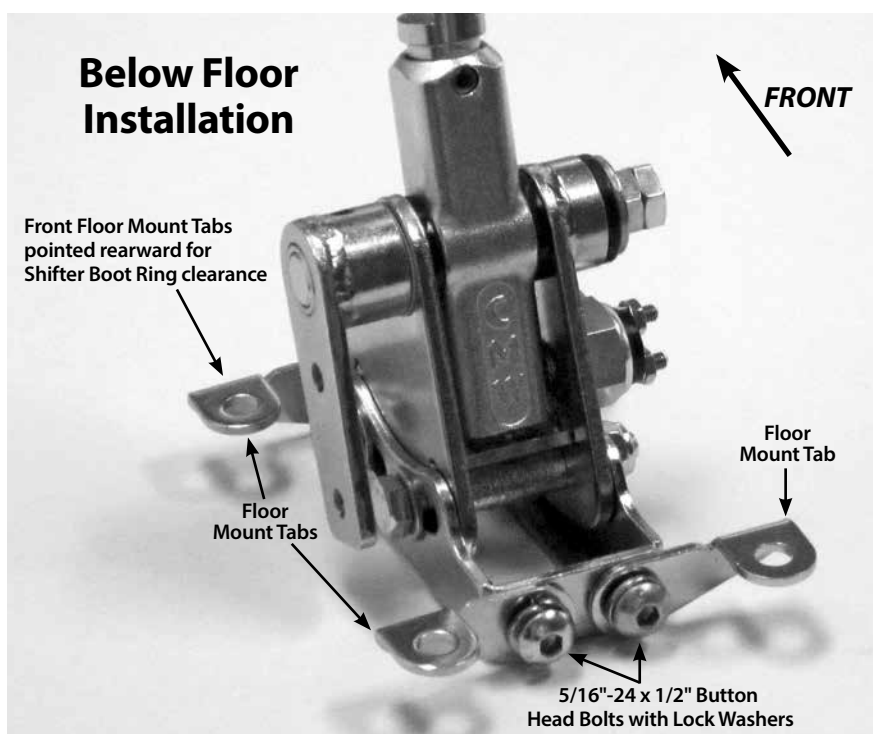

Fig. 2

Step 2, continued: There are three different quad arms to choose from: straight, 1-1/4" offset or 2-1/2" offset. Choose the quad arm that aligns most closely to the driver side edge of the transmission pan. It is not necessary that the quad arm be perfectly aligned with the edge of the transmission pan. The rod ends allow for a certain amount of misalignment.

Be aware that the quad arm you choose will affect the size and location of the slot that will need to be cut in the floor.

NOTE: Some round shifter boots and boot rings will NOT work with a Clayton Machine Works Shifter if the Shifter Boot and Boot Ring are also mounted directly on the floor.

Some shifter boots and boot rings will NOT work with the (largest) 2.5" offset quad arm on a Clayton Machine Works Shifter if the Shifter Boot and Boot Ring are also mounted directly on the floor.

Step 3: There are two pairs of floor mount tabs in the Shifter Kit. Which pair goes where will depend on if you are mounting the Shifter above or below the floor. See Fig. 2 to determine how the floor mount tabs need to be positioned for your particular application.

The floor mount tabs on the rear of the Shifter **must** be installed with the ears pointing towards the rear of the vehicle. You may install the front floor mount tabs facing either direction, but installing the front floor mount tabs pointing rearward is less likely to interfere with fitment of a shifter boot and boot ring.

Attach the floor mount tabs to the floor mount mounting bracket as shown in Fig. 2 with the 5/16"-24 x 1/2" button head bolts and lock washers. Leave the bolts loose enough so that adjustments can be made later during the installation.

Step 4: Tremec Style Lever - If your Shifter did not come with the Shifter Lever already installed, install the Shifter Lever using the 3/8"-24 bolts that came with the Shifter Lever. Fig. 3

All: Make sure the two 5/16"-24 x 2-1/4" hex head bolts and nylock nuts that are in the curved, slotted holes in the floor mount mounting bracket are tight. Place the Shifter in the desired location on the vehicle's floor. Make sure the Shifter Lever will not interfere with the dash when in Park, or with the seat when in low gear. The shifter assembly may be tilted forward or backward if needed by loosening the nylock nuts on the two 5/16"-24 x 2-1/4" hex head bolts that are in the curved, slotted holes in the floor mount mounting bracket. Retighten the nylock nuts once you have the shifter assembly at the angle you want. Fig. 4

Step 5: Determine the size and location of any opening(s) that need to be cut in the floor in order to mount the shifter assembly and allow full travel of the quad arm you are going to use. It may be useful to temporarily mount the quad arm to the quad lever and move the shifter lever through its full range of motion, in order to help determine where the cuts need to be made.

Cut those openings now.

Step 6: Place the shifter assembly in position on the vehicle. Push the floor mount tabs flush against the floor, and mark the center of the bolt holes in the floor mount tabs onto the floor. Center punch the marks, and drill four 5/16" diameter holes.

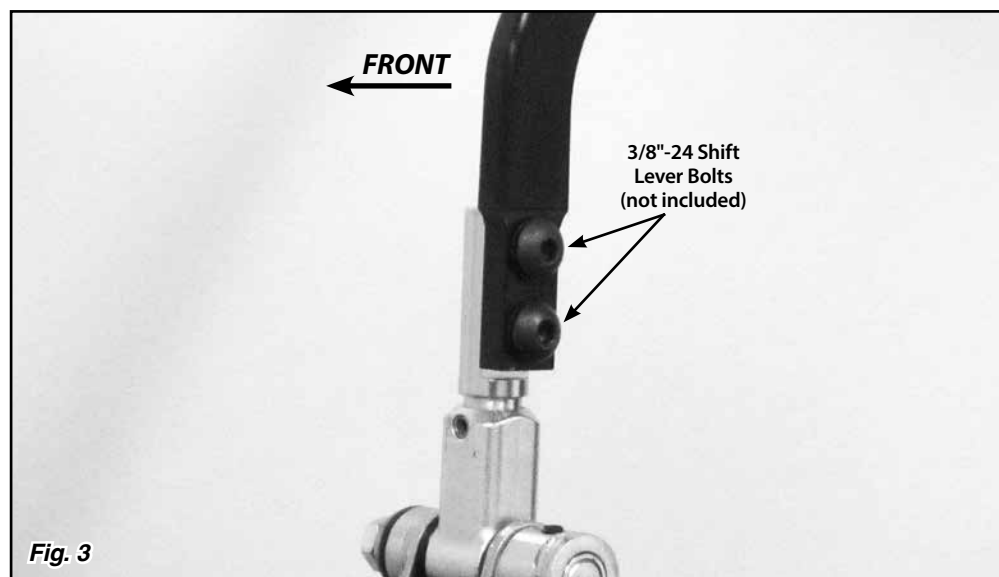

Fig. 3

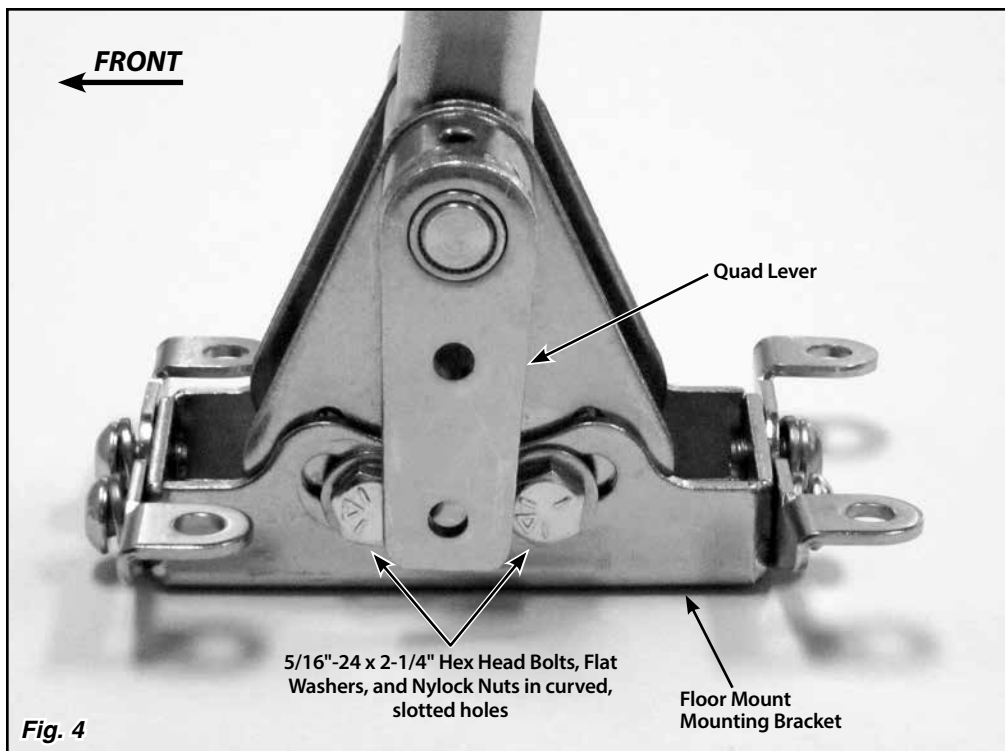

Fig. 4

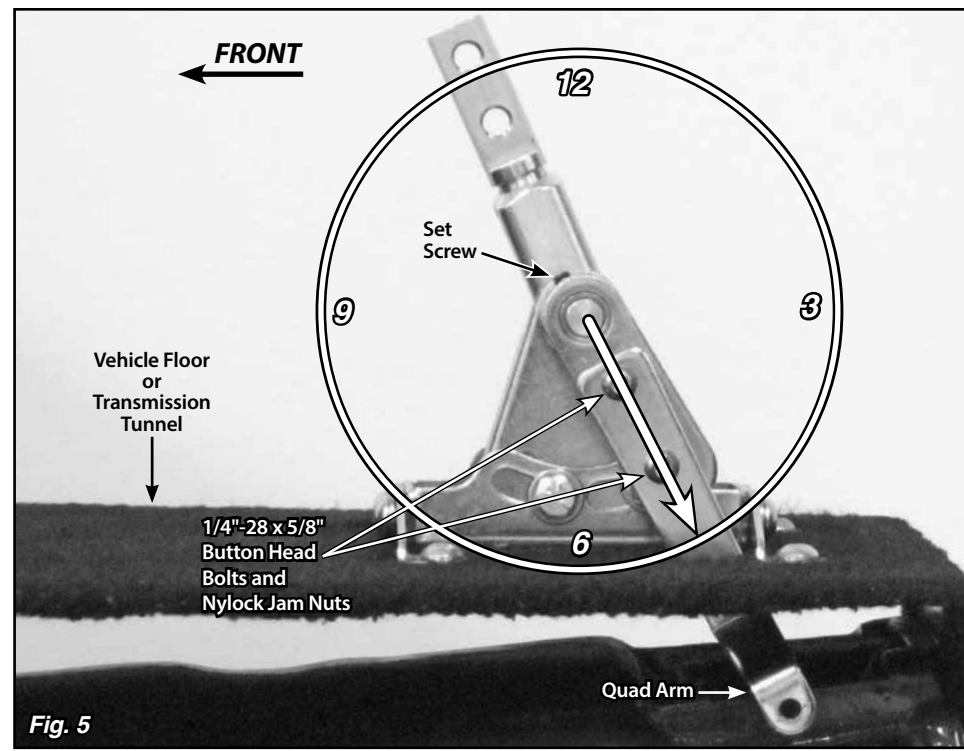

Fig. 5

Step 7: Attach the floor mount tabs to the floor using four 5/16"-24 x 1/2" button head bolts and nylock jam nuts. Once the shifter assembly is mounted to the floor, tighten the floor mount tab to floor mount mounting bracket bolts.

Step 8: Make sure the Shifter Lever is in the Park position. Position the quad arm in place on the quad lever with the bolt holes aligned. Check for interference with the driver side rear floor mount tab or the vehicle floor. With the shifter lever in Park, you want the quad arm to be as close to the 4:30 – 5:00 position as the floor mount tab will allow, without the quad arm touching the floor mount tab or floor.

If the quad arm is not in the proper position, loosen the set screw in the top of the quad lever with a 1/8" Allen wrench and slide the quad lever off of the shaft. The shifter assembly may have to be removed to do this, depending on how the Shifter is mounted and how large the opening is in the tunnel. Reposition the quad lever on the shaft as close to 4:30 – 5:00 as the floor mount tab allows, and retighten the set screw. **Fig. 5**

Install the quad arm onto the quad lever using the two 1/4"-28 x 5/8" button head bolts and nylock jam nuts. **Fig. 5**

Step 9: Remove the forward-most bolt from the driver side of the transmission pan, and the bolt that is the furthest to the driver side on the front of the transmission pan. Remove the masking tape from the 5/16"-18 x 1-1/4" bolts on the provided linkage arm assembly. Install the linkage arm assembly onto the underside of the front driver side corner of the transmission pan. **Fig. 6**

Step 10: Verify that the linkage arm and rod ends are assembled correctly, with the short threaded rod on the outside of the linkage arm, away from the transmission. **Fig. 7** If not, rearrange the parts as needed in order to match **Fig. 7**. The bolt can be installed from either side, but make sure there is a flat washer to the outside of each rod end. Tighten the 5/16"-24 x 7/8" button head bolt and nylock jam nut at the bottom of the linkage arm. Then, loosen the 5/16"-24 nylock jam nut just enough so that the linkage arm can pivot freely.

Step 11: Make sure the transmission is in Park. The factory trans arm should be pointed to the driver side of the vehicle and slightly towards the rear, at approximately the 4:30 to 5:00 position if looking down on it from above, as shown in **Fig. 8**. Connect the rod end on the short threaded rod to your factory trans arm, using the provided 1/4"-28 x 1" button head bolt with flat washer and nylock nut. Adjust the rod ends in or out on the short threaded rod as needed in order to get the linkage arm pointed up at approximately the 1:00 position. If any part of the shifter linkage interferes with the kickdown lever or linkage, you can position the linkage arm a little higher. **If may be necessary to bend or shorten the short threaded rod in order to get the linkage arm in the correct position.**

(continued on Page 4)

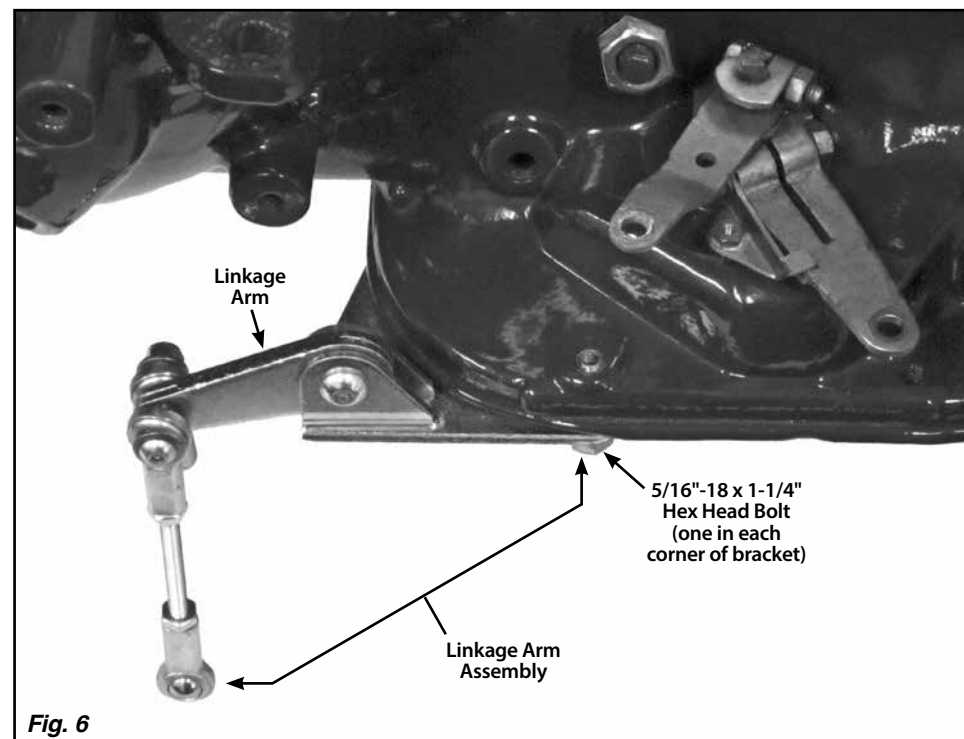

Fig. 6

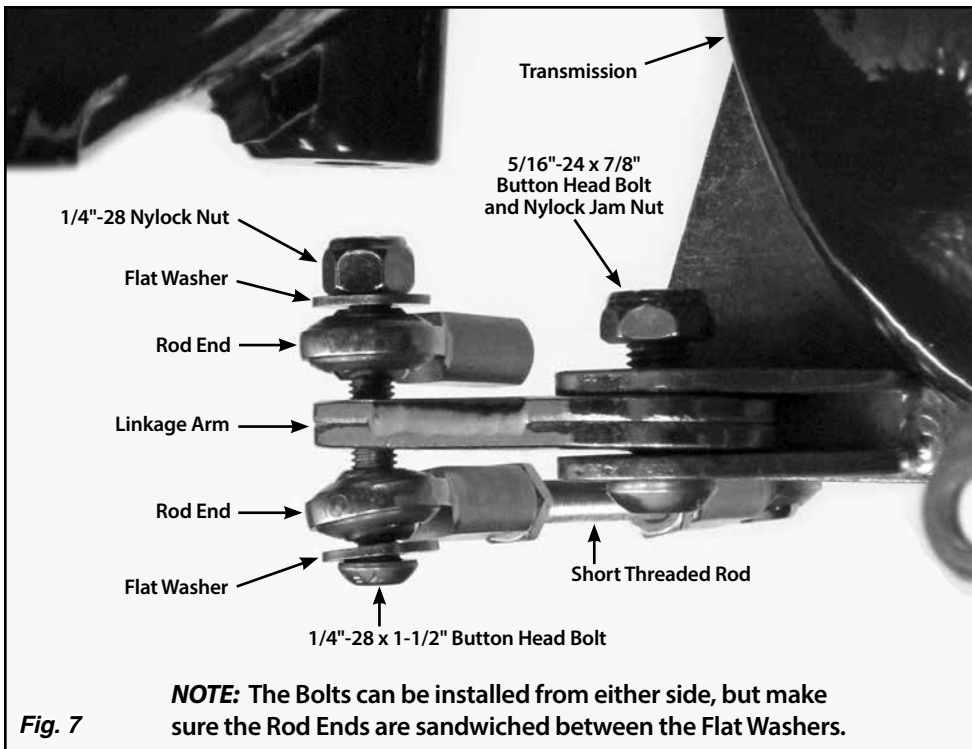

Fig. 7

NOTE: The Bolts can be installed from either side, but make sure the Rod Ends are sandwiched between the Flat Washers.

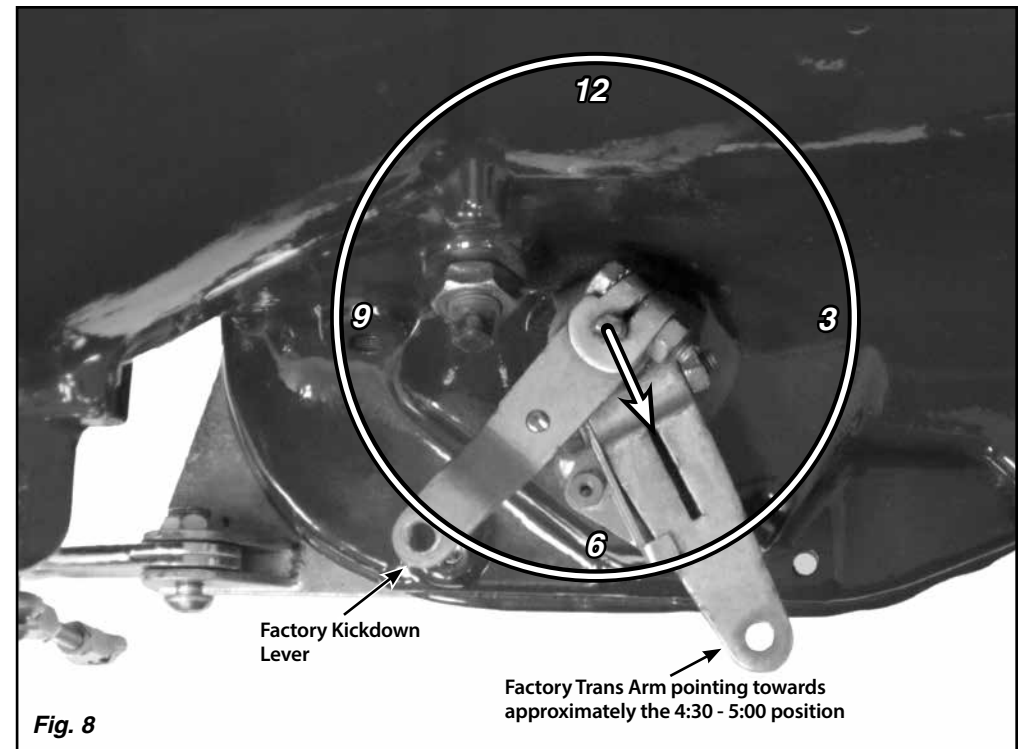

Fig. 8

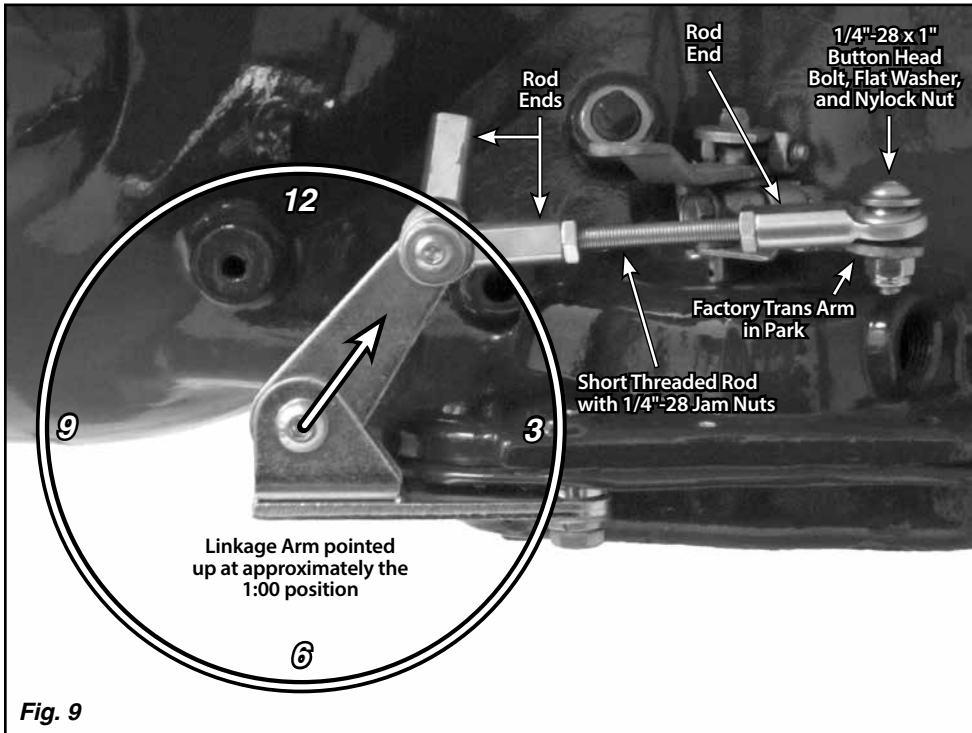

Fig. 9

Step 11, continued:

Once you have it adjusted correctly, tighten the jam nuts on the short threaded rod. Then, make sure there are flat washers to the outside of both rod ends on the short threaded rod, and tighten the 1/4"-28 nylock nut at the top of the linkage arm. **Fig. 9**

Step 12: The long threaded rod will connect the quad arm to the linkage arm. Check to make sure that nothing will interfere with the travel of the long threaded rod.

If there is any interference, the long threaded rod can be bent slightly as needed.

Verify that both the Shifter and the transmission are in the Park position. Measure center-to-center between the 1/4" holes in the quad arm on the Shifter and the button head bolt in the top of the linkage arm. Subtract 1-3/4". **Fig. 10** This is the length you will cut the long threaded rod. Use a hacksaw or cutoff wheel to shorten the long threaded rod. Then, de-burr the cut end of the rod.

Step 13: Verify that both 1/4"-28 jam nuts are on the long threaded rod. Thread one end of the long threaded rod into the rod end on the linkage arm, and install a rod end onto the opposite end of the long threaded rod. Attach that rod end to the outside of the quad arm using the 1/4"-28 x 1" button head bolt, flat washer, and nylock nut as shown in **Fig. 11**. The 1/4"-28 x 1" button head bolt can be installed from either direction, but make sure the rod end is sandwiched between the flat washer and the quad arm.

Step 14: Check the adjustment of the shifter linkage by placing the shifter lever all the way forward into the Park position.

While the Shifter is in the Park position, make sure the transmission is firmly in the "Park" detent, with no tension on the threaded rod. You can verify this by removing the 1/4"-28 x 1" button head bolt with nylock nut that attaches the rod end to the quad arm. Make sure the hole in the rod end exactly aligns with the hole in the quad arm. The bolt should pass freely through both holes at the same time without binding. Do not force the holes to line up.

If the holes are not aligned, screw the rod end in or out just enough to be able to slide the bolt in and out without putting tension on the threaded rod. Make sure that the quad arm and linkage arm do not move during the adjustment procedure. Use this adjustment routine until the bolt will pass freely in and out of both the rod end and the quad arm. Reinstall the 1/4"-28 nylock nut and the flat washer onto the bolt and tighten.

Once you have the shifter linkage adjusted correctly, tighten the jam nuts on the threaded rod. **Fig. 12**

Neutral Safety Switch Wiring

NOTE: The neutral safety switch will have one or more washers under it. The washer(s) are used to adjust the depth of the neutral safety switch for proper operation. If the neutral safety switch is ever removed for any reason, you **MUST** reinstall the same washer(s) with the neutral safety switch to maintain the adjustment. **Fig. 13**

The Shifter's neutral safety switch is a simple on/off, non-directional switch. The switch passes current (turns on) when the ball is pushed in. It does not pass current (turns off) when the ball is out at its at-rest position.

Step 15: Connect the neutral safety switch between your ignition switch and starter circuits. Check the wiring of your fuse panel:

- **If there are (2) connections for a neutral safety switch**, run a #12 (or heavier) stranded wire from these terminals in your fuse panel to the (2) terminals on the neutral safety switch. That completes the neutral safety switch wiring.
- **If your fuse panel does not have neutral safety switch connections**, locate the wire going from the ignition switch to the starter. If GM color codes are used, this wire will usually be purple. After locating the wire, disconnect it from the starter. It must be cut and routed from the ignition switch to one of the neutral safety switch terminals, and from the other neutral safety switch terminal to the same stud on the starter where the original wire was removed. If the wire must be lengthened, be sure to use wire that is at least the same size or larger than the original.

Step 16: Reconnect the negative battery cable and check operation. Make sure that the engine will not start in Reverse or any forward gear.

If it does, try adding a thin washer or shim (any material is OK, such as gasket material) under the neutral safety switch. If the engine will not start in Park or Neutral, remove one of the washers from underneath the neutral safety switch, and try it again. Tighten all brackets and bolts correctly and securely and there should be no movement or maladjustment. If you have any questions after following this procedure, please call Clayton Machine Works Technical Support.

