

LS Classic Series By Lokar 57 Fuelie & 62 Fuelie Intake Manifold Installation Instructions

Building American Quality... With A Lifetime Warranty!®

TOLL FREE 1-877-469-7440 • tech@lokar.com • www.lokar.com

LS Classic Series By Lokar 57 Fuelie & 62 Fuelie Intake Manifold Installation Instructions

General Installation Notes:

Please read these instructions completely before beginning the installation. If you have any questions, please call.

Before beginning the installation, disconnect the negative battery cable and use wheel chocks to block the vehicle's wheels.

Make sure the engine, transmission, body and frame are all properly grounded.

Refer to Fig. 1 and Fig. 2 for the component names.

The LS Classic 57 Fuelie & 62 Fuelie Intake Manifolds are designed for GM LS Gen III and Gen IV engines used in retrofit engine installations into older classic/high performance cars and trucks. The Intake Manifolds are specifically designed for use with LS3/L92 rectangular port cylinder heads. If you purchased the Intake Manifold for an engine equipped with cathedral port cylinder heads, a pair of Cathedral Port Head To LS3 Intake Adapters are included and will need to be installed.

The Intake Manifolds will accept A GM four bolt flange, 92mm drive-by-wire throttle body (not included). Other throttle bodies may require modification or the purchase of an additional adapter plate.

Emissions Equipment:

LS Classic 57 Fuelie & 62 Fuelie Intake Manifolds DO NOT accept any emission control devices. This part is not legal for sale or use on pollution controlled motor vehicles.

The Intake Manifold has been temporarily assembled for shipping purposes only. The Intake Manifold must be disassembled before beginning the installation.

Intake Manifold Disassembly

Step 1: Remove the decorative copper fuel injector lines.

Step 2: Disconnect the four ends of the black -4 AN fuel hard lines from each of the four fuel rails.

Step 3: Using the 3/16" T-handle wrench, remove the 1/4"-20 x 3/4" socket head bolts that attach each fuel rail bracket to the lower manifold. Note the position of each of the fuel rails as each one has to go back in its original location.

Step 4: Remove the six 3/8"-16 flange nuts from the studs on the lower manifold, and remove the upper manifold. Be careful to not disturb the position of the studs, as they are set at a specific height and permanently installed with thread locking compound.

Step 5: Remove the two black -4 AN fuel hard lines from the center of the lower manifold.

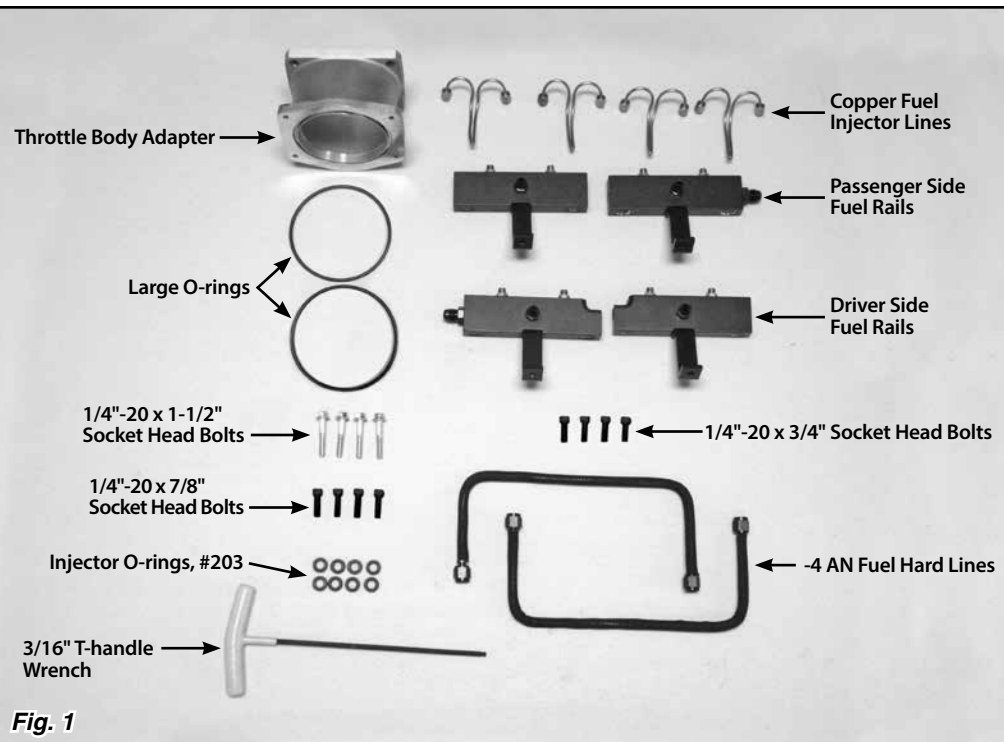

Fig. 1

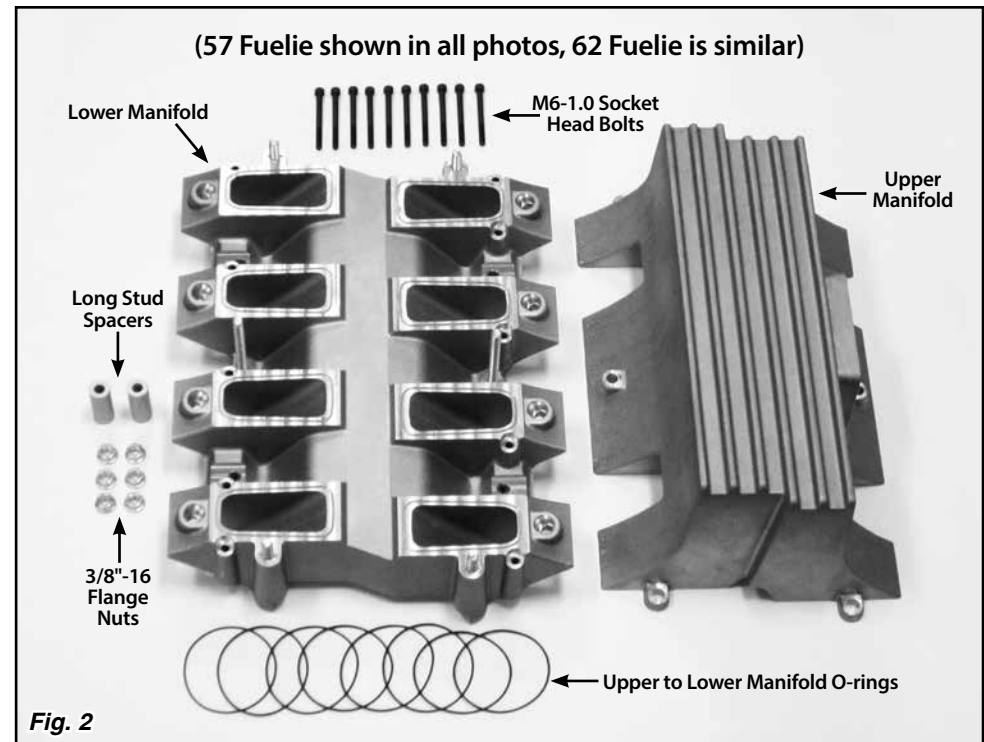

Fig. 2

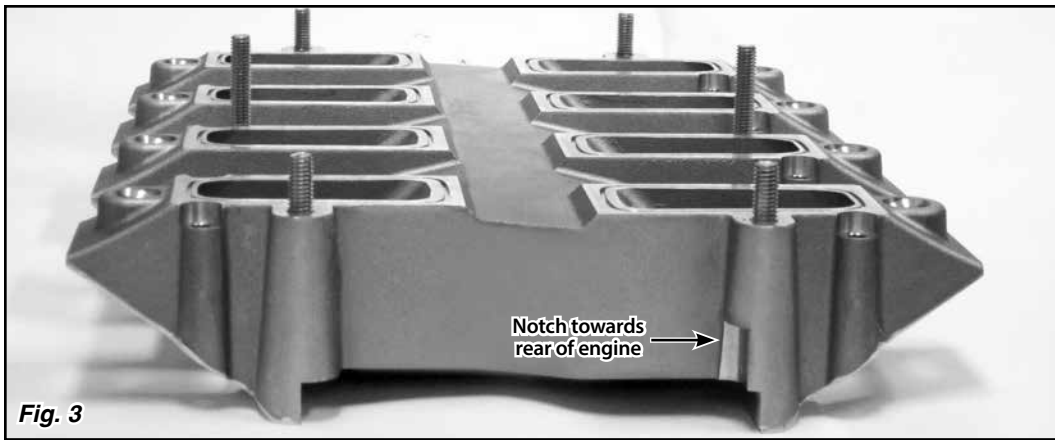

Fig. 3

Intake Manifold Test Fit

Step 1: If you are using an LS Classic Valley Plate and/or Distributor and Plug Wire Set, install them before installing the Intake Manifold. Install the distributor cap so the metal points adjustment window is facing the firewall. Leave the distributor mounting bolts loose and slide the distributor back towards the firewall as far as possible.

Step 2: Before installing the lower manifold, make sure the cylinder head surface is clean and completely free of any debris or residue.

Step 3: If you are using our Cathedral Port Head To LS3 Intake Adapters, they must be placed on the cylinder heads before installing the lower manifold.

Install the lower manifold without the O-rings, with the notch in **Fig. 3** to the rear of the engine. Make sure the lifter valley plate does not interfere and prevent the lower manifold from sitting flat against the cylinder heads (or Intake Adapters, if applicable).

Step 4: Check the alignment of the port openings in the lower manifold and cylinder head. Install the ten M6-1.0 socket head bolts through the lower manifold and thread them into the cylinder heads. Make sure the bolts do not bind or bottom out in the cylinder head.

Step 5: Set the upper manifold into place, and thread on a couple of the 3/8"-16 flange nuts finger tight. Install the throttle body adapter using the 1/4"-20 x 7/8" socket head bolts. Lightly snug down the bolts using the 3/16" T-handle wrench.

Step 6: Install the throttle body (not included) using the 1/4"-20 x 1-1/2" socket head bolts, lightly snugging the bolts down with the 3/16" T-handle wrench. Lastly, install the air cleaner to ensure there are not any fitment issues. Check for possible interference with your vehicle's master cylinder and/or power booster, firewall, and hood closing position.

Once you have confirmed the fit of the Intake Manifold, disassemble and remove everything back down to the bare cylinder heads.

Installation

Step 1: Install the Cathedral Port Head To LS3 Intake Adapters with their O-rings, if applicable.

Install eight LS3 intake manifold O-rings (not included) in the grooves on the lower manifold. If the O-rings will not stay in the grooves, apply a light coat of grease to the O-rings to help them stay in place.

Step 2: Place the lower manifold on the cylinder head (or Intake Adapter) mounting surfaces, with the notch in **Fig. 3** to the rear of the engine. Take extra care to make sure all of the O-rings remain installed in the grooves.

Step 3: Apply a drop or two of engine oil to the threads of the ten M6-1.0 socket head bolts. Install the bolts through the lower manifold and thread them into the cylinder heads. Following the tightening sequence diagram in **Fig. 4**, snug the bolts down lightly, just until the O-rings are slightly compressed.

NOTE: The threads in the aluminum cylinder head will fail if the bolts are over-torqued. Carefully follow the procedure below when tightening the M6-1.0 socket head bolts.

Step 4: Torque the M6-1.0 socket head bolts in two steps. Following the sequence in **Fig. 4**, tighten all of the M6-1.0 socket head bolts to 50 lb.-in. (4.2 lb.-ft.). Then, follow the sequence in **Fig. 4** again to tighten the bolts to 106 lb.-in. (8.8 lb.-ft.).

Step 5: Place the long stud spacers onto the long studs in the center of the lower manifold, one on each side. **Fig. 5**

Step 6: Install eight (8) upper to lower manifold O-rings into the grooves on the lower manifold. **Fig. 5**

Step 7: Place the two black -4 AN fuel hard lines in the center of the lower manifold, with the nuts pointing out towards the fuel rail position. **Fig. 6**

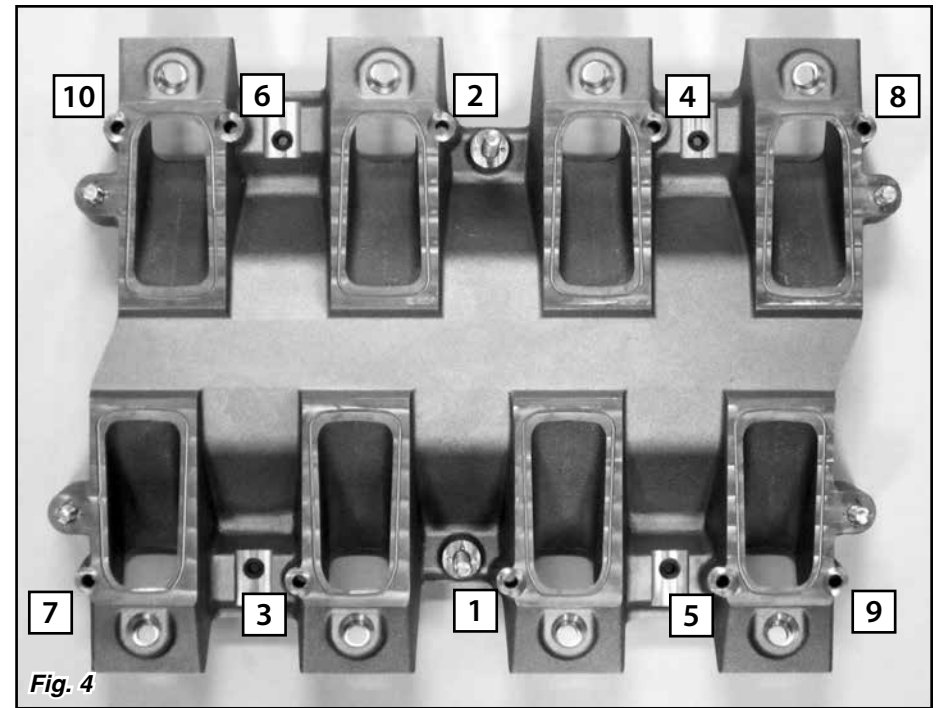

Fig. 4

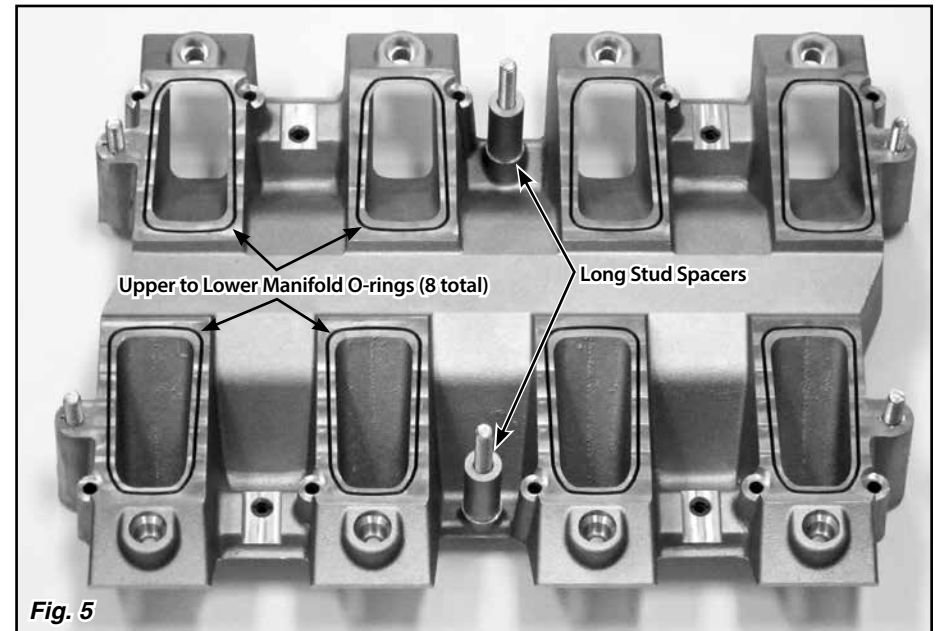
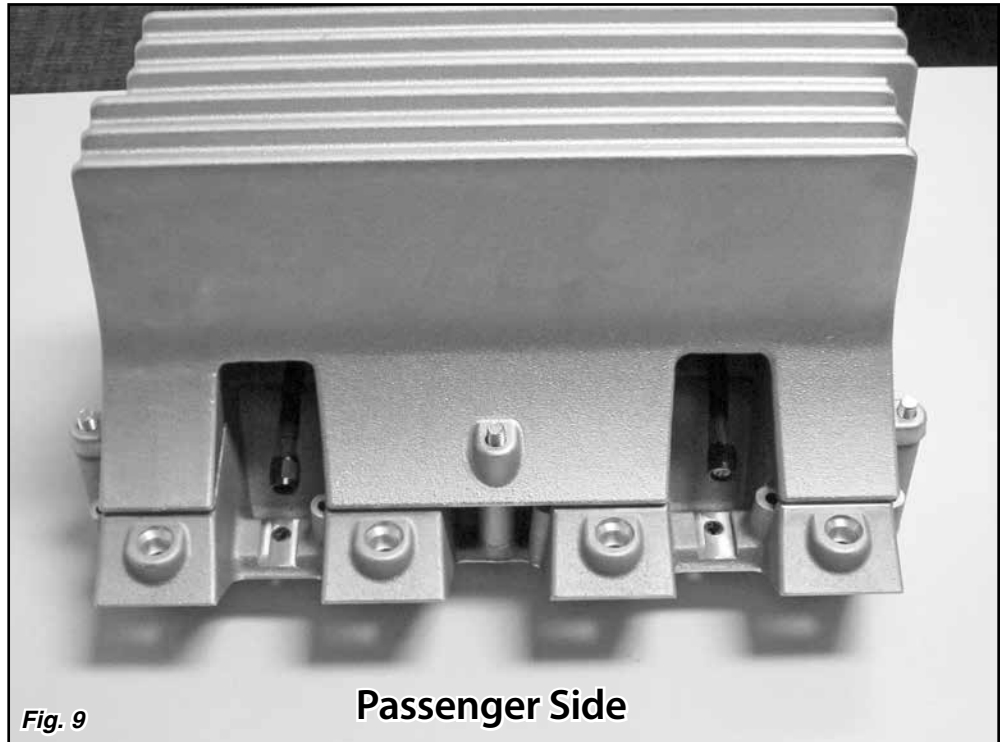
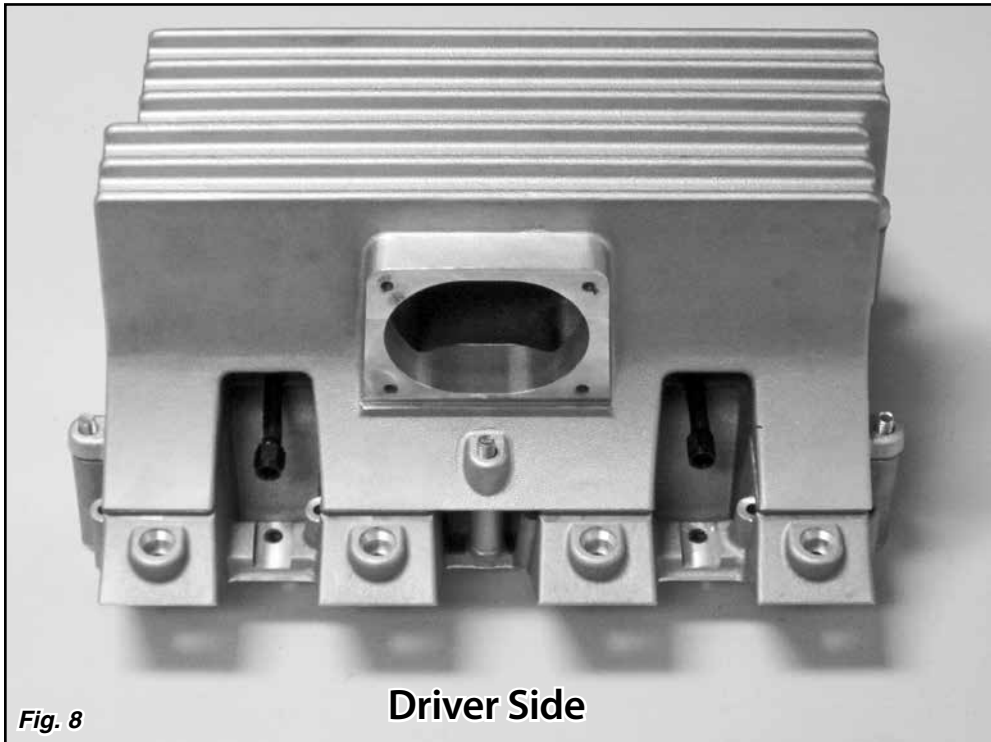
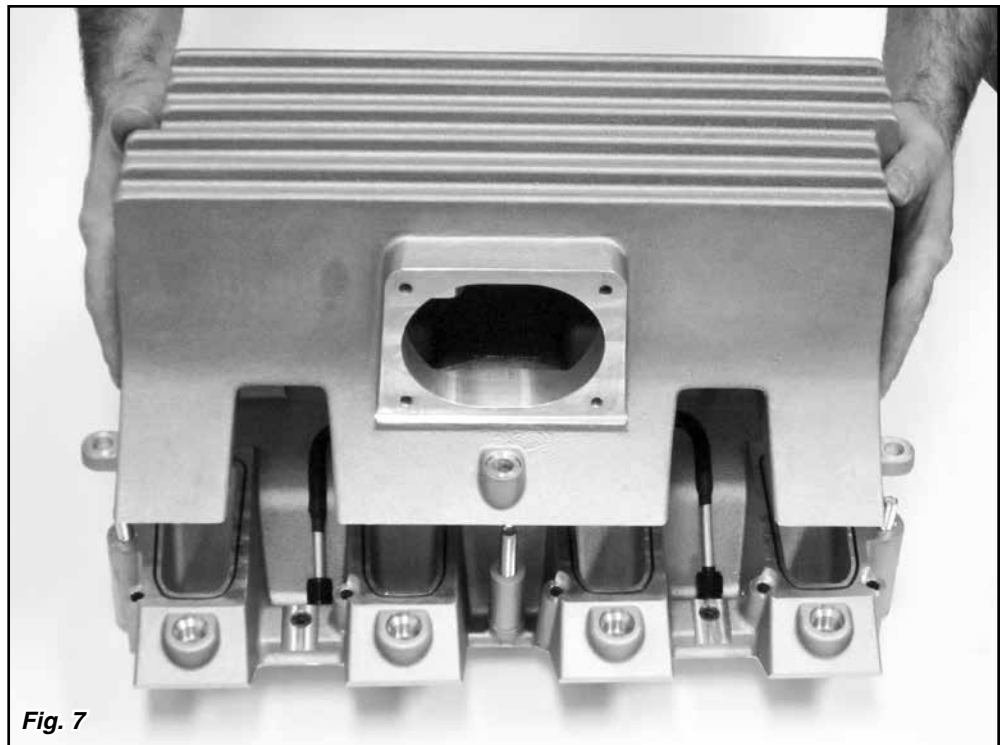
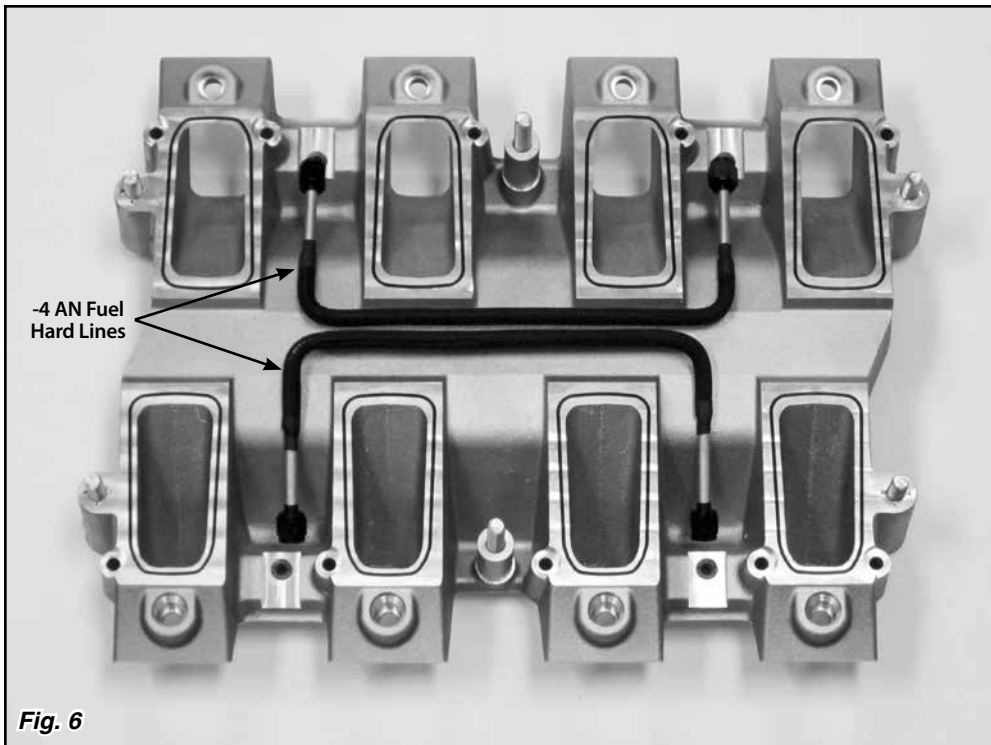

Fig. 5

Step 8: Install the upper manifold onto the lower manifold. Make sure all of the upper to lower manifold O-rings stay in place, and the -4 AN fuel hard lines remain in position and are not pinched or damaged. **Figs. 7, 8 and 9.** If you are using the LS Classic Distributor and Plug Wire Set, make sure you have enough clearance and do not damage the distributor cap.



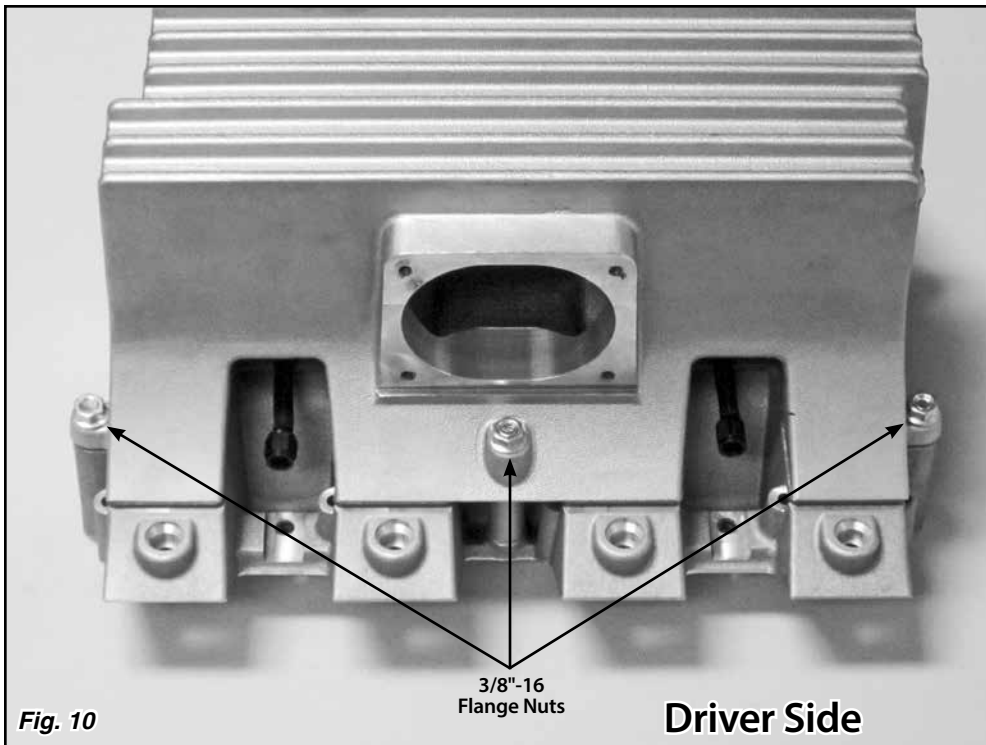

Fig. 10

3/8"-16
Flange Nuts

Driver Side

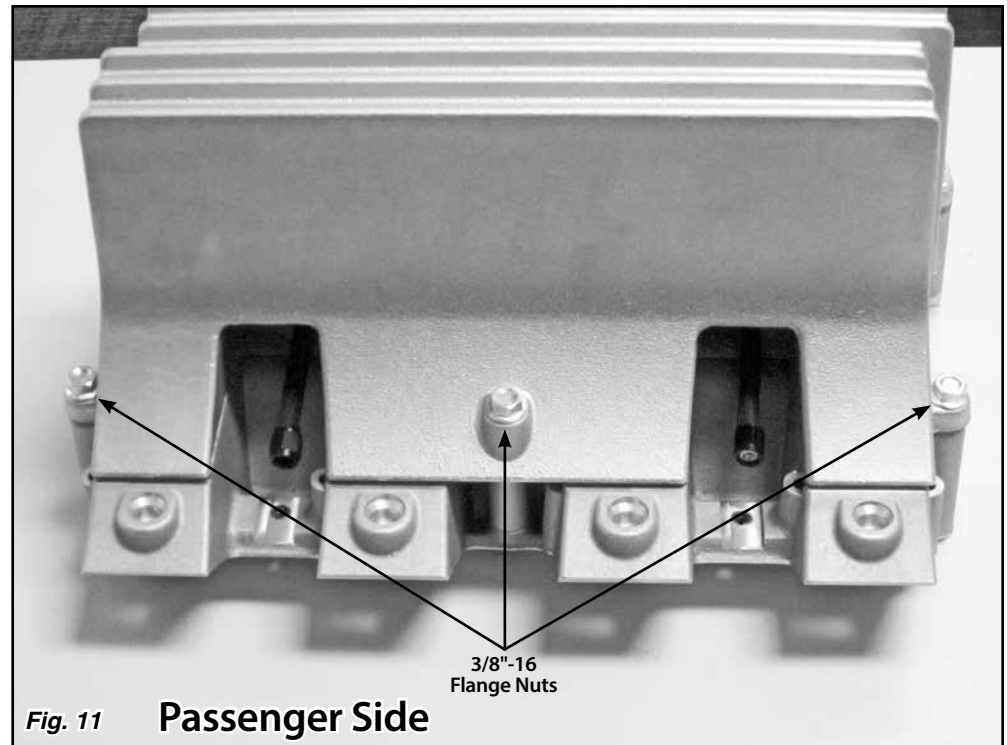

Fig. 11

3/8"-16
Flange Nuts

Passenger Side

Step 9: Install the six 3/8"-16 flange nuts (9/16" wrench size) onto the manifold. Tighten the two center nuts to 20 lb.-ft. Then, tighten the corners in a crisscross pattern to 20 lb.-ft. **Figs. 10 and 11**

Step 10: If you have installed the LS Classic Distributor and Plug Wire Set, slide the distributor into the desired position and tighten the mounting bolts.

Step 11: Install one of the large O-rings into the groove on the oval side of the throttle body adapter. Place a 1/4"-20 x 7/8" socket head bolt into each of the four flange holes on the oval end of the throttle body adapter. **Fig. 12**

Step 12: Note one edge of the throttle body side of the throttle body adapter flange is wider than the other edge. Install the throttle body adapter onto the upper manifold with the wider edge of the flange at the top. Tighten the socket head bolts using a crisscross pattern in two steps, 7 lb.-ft. for the first step and 12-15 lb.-ft. for the second step. **Fig. 13**

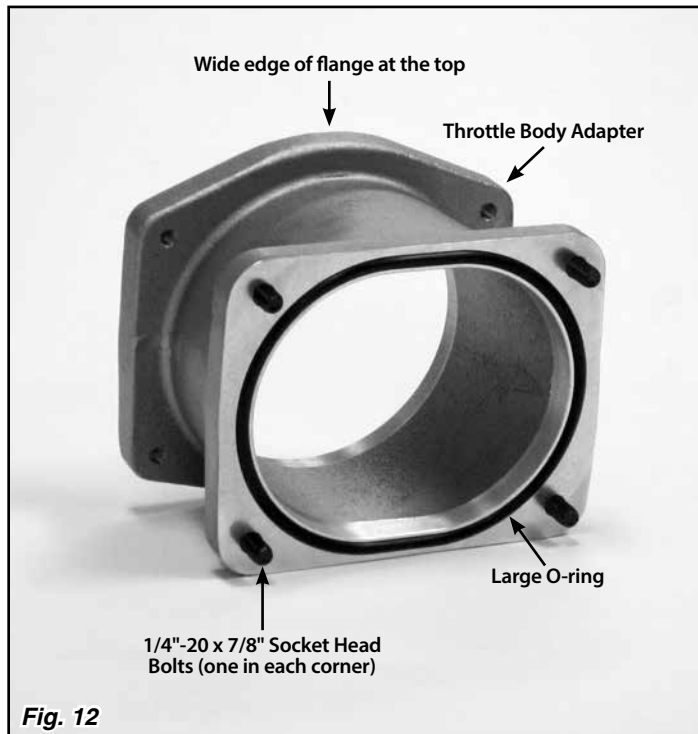

Fig. 12

Wide edge of flange at the top

Throttle Body Adapter

Large O-ring

1/4"-20 x 7/8" Socket Head Bolts (one in each corner)

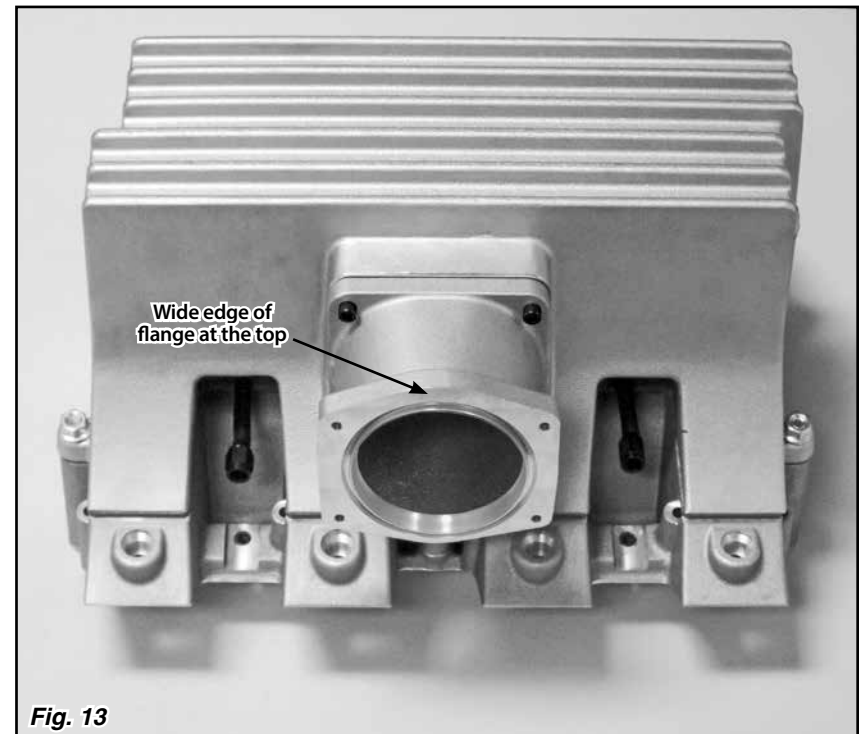

Fig. 13

Wide edge of
flange at the top

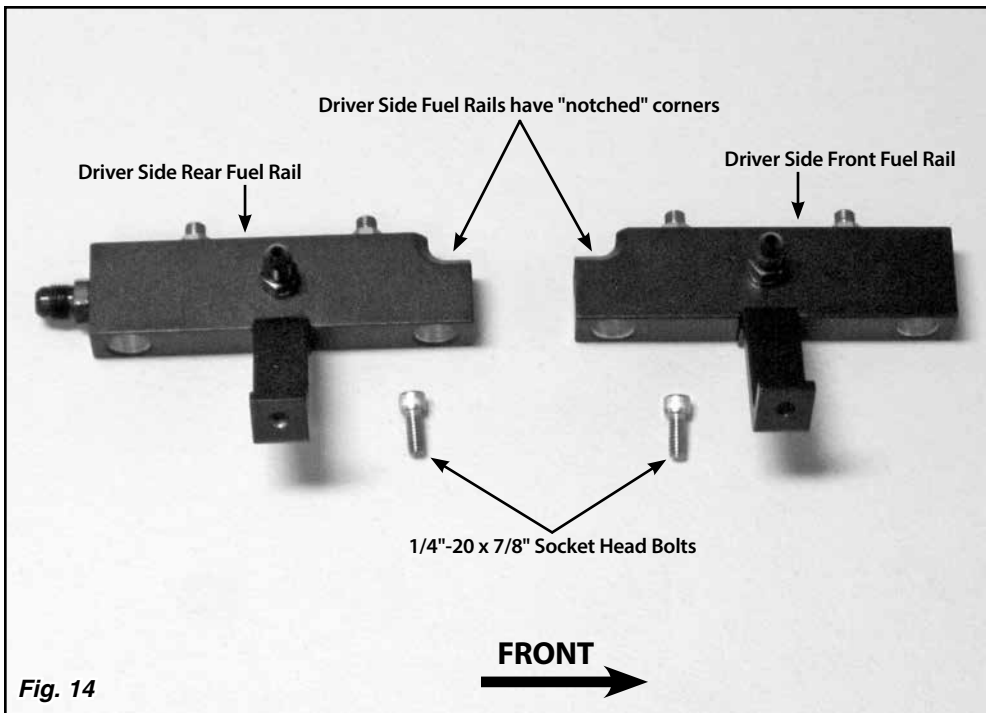

Fig. 14

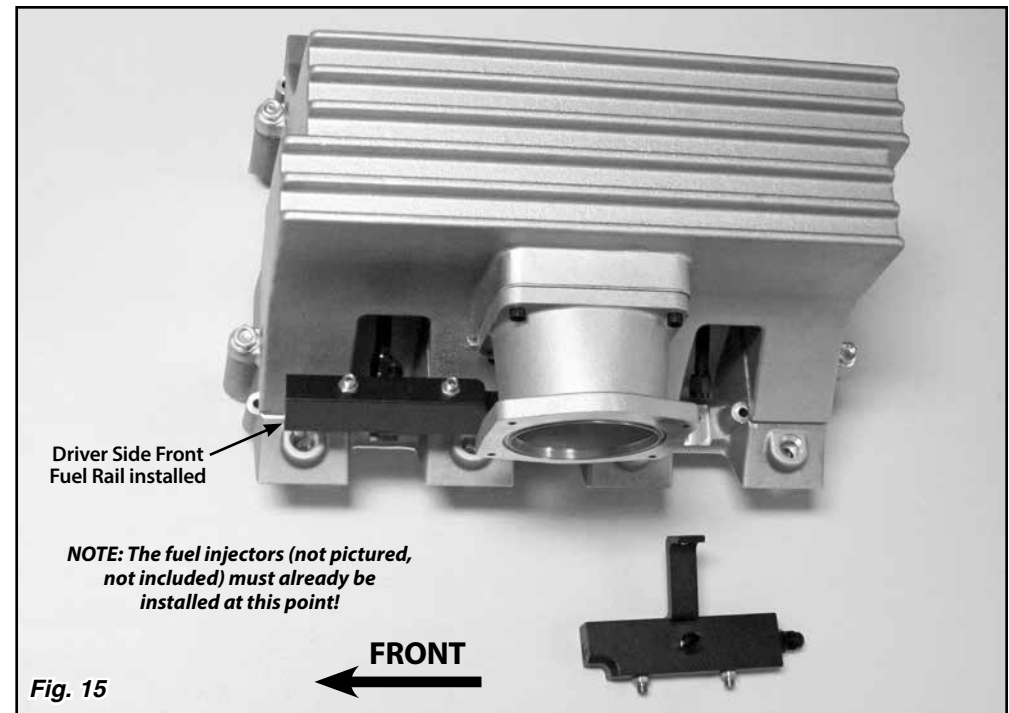

Fig. 15

NOTE: The LS Classic 57 Fuelie and 62 Fuelie Intake Manifolds are designed to work with the stock, short GM, LS3/LS7 EV6 fuel injectors. The fuel injectors are **NOT** included with the kit and must be purchased separately. **These intake manifolds WILL NOT work with any other style of fuel injectors!**

Step 13: Remove the bottom O-ring from each of the fuel injectors. Install one of the provided injector O-rings onto the bottom of each injector.

Step 14: Determine the correct position of the four fuel rails on the lower manifold. Note the driver side rear and passenger side rear fuel rails (with the -6 AN fittings on the ends) will be installed with the -6 AN fittings pointing towards the rear of the engine. Two of the fuel rails are "notched" in one corner to provide clearance for the throttle body adapter and will be installed on the driver side of the manifold. **Fig. 14**

Step 15: Apply a silicone lubricant to the O-ring on the inlet end of the fuel injectors, and insert the fuel injectors into the ports in each fuel rail. To insert the injector without tearing the O-ring, gently rock the injector in the inlet of the port while applying pressure to the injector.

Step 16: Position the injectors to properly orient the wiring plugs. Apply silicone lubricant to the bottom injector O-rings, and insert the injectors into the injector bosses in the lower manifold by applying gentle downward pressure on the fuel rail. **Fig. 15**

Do this for all four fuel rails.

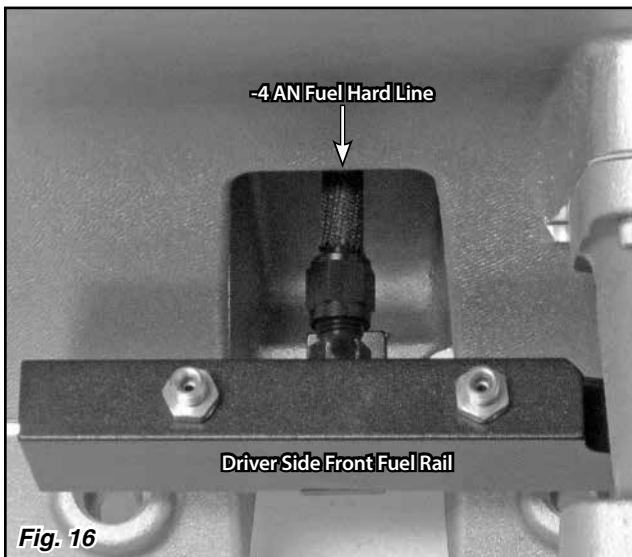

Fig. 16

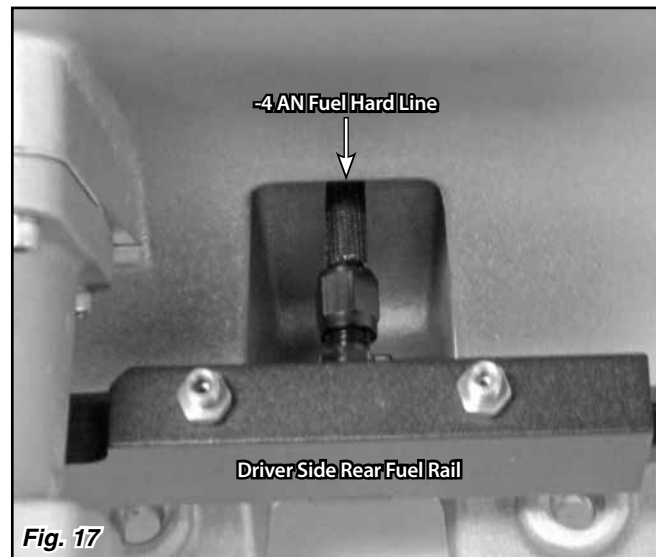
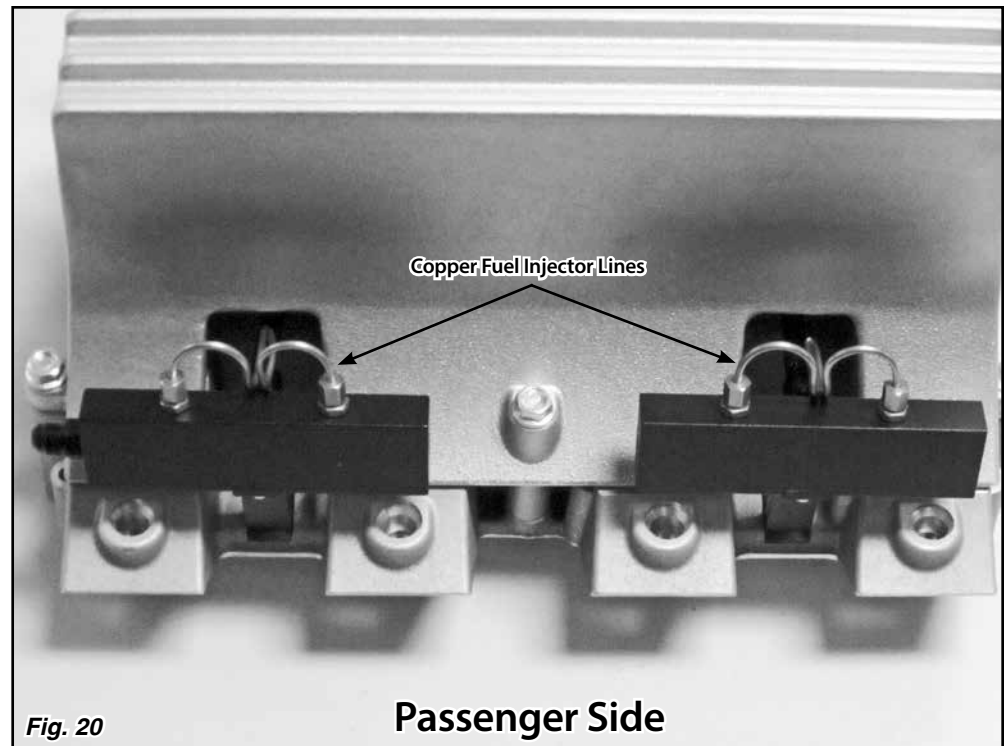
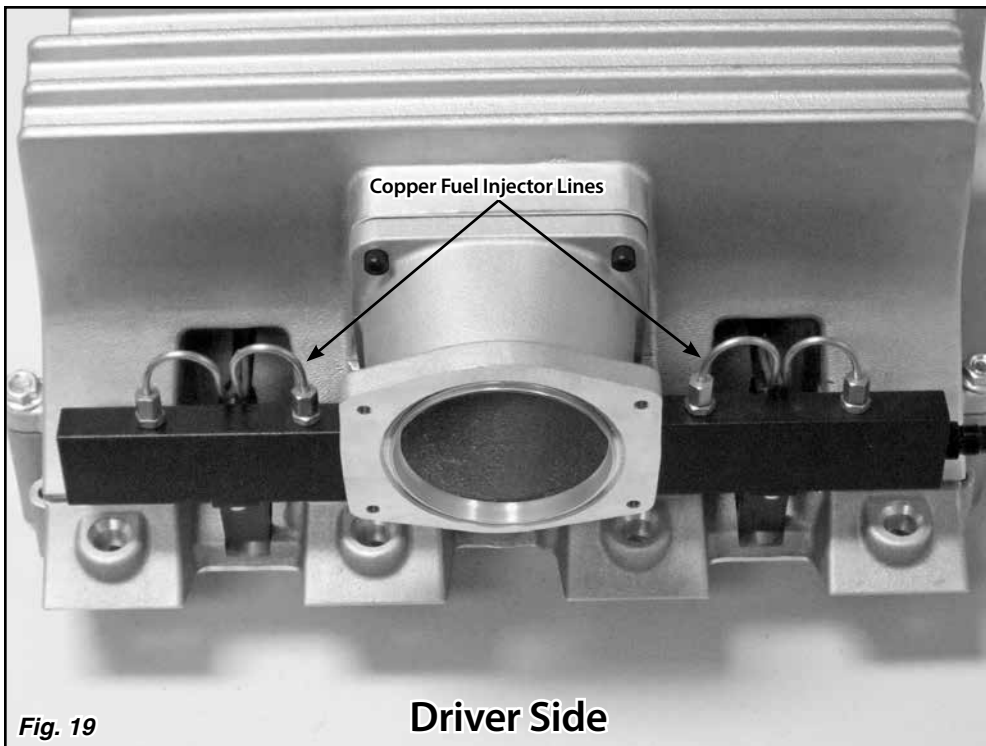

Fig. 17



Fig. 18



Step 17: Once all of the injectors are inserted into the lower manifold, loosely attach the -4AN fuel hard lines to the fuel rails. Install each fuel rail bracket onto the lower manifold using the 1/4"-20 x 3/4" socket head bolts. Snug the bolts down, but do not fully tighten the bolts at this time.

Step 18: Make sure the fuel injectors are properly positioned. Ensure the injectors are "floating" on the O-rings. Rotate each injector back and forth to confirm there is no load on the injector bodies. The injectors should have 0.020-0.040" of end play and the O-ring seals must stay in the O-ring seal counter bores.

Step 19: Tighten the 1/4"-20 x 3/4" socket head bolts holding the fuel rail brackets in two steps. Tighten to 7 lb.-ft. for the first step, and to 12-15 lb.-ft. for the second step. Then, tighten the -4 AN fuel hard line nuts. **Figs. 15, 16, 17, and 18**

Step 20: Once the fasteners are tightened, re-check and ensure the injectors are "floating" on the O-rings. Rotate the injectors back and forth to confirm there is no load on the injector bodies.

NOTE: Fuel injectors that are not installed correctly can cause a fuel leak! Carefully inspect for leaks when fuel is initially pressurized, and before attempting to start the engine.

Step 21: Connect the fuel feed lines to the -6 AN fittings on the rear fuel rails.

Step 22: Reinstall the four decorative copper fuel injector lines. **Figs. 19 and 20** Make sure you do not over tighten the brass nuts. There will be no fuel in the copper fuel injector lines, and they cannot leak.

Step 23: Install the remaining large O-ring into the groove in the throttle body adapter. **Fig. 21** Install the throttle body (not included) using the 1/4"-20 x 1-1/2" socket head bolts. Consult the throttle body manufacturer's installation instructions for proper installation and torquing procedures.

Step 24: With the throttle body mounted on the throttle body adapter, check to be sure all wiring, fuel lines, and vacuum lines have adequate clearance from the intake manifold and each other.

Step 25: Before starting the engine, run the fuel pump to build fuel pressure. **Confirm there are no fuel leaks and the fuel pressure is correct!** Always have a fuel-rated (Class B) fire extinguisher handy when you start an engine after working on the fuel system.

Step 26: Start the engine, and again **confirm there are no fuel leaks.** In the event you do find a fuel leak, immediately turn the engine off, and repair the source of the leak before restarting the engine.

