



QUALITY... PLAIN & SIMPLE®

## GM Hi-Tech Kickdown Kit Installation Instructions

For TH350, 700-R4, TH200, TH200-4R, and 4L60

### General Installation Notes:

Please read these instructions completely before beginning the installation. If you have any questions, please call.

Before beginning the installation, disconnect the negative battery cable and use wheel chocks to block the vehicle's wheels.

Make sure the engine, transmission, body and frame are properly grounded. We recommend using anti-seize lubricant on all aluminum threads.

**NOTE:** This Lokar Kickdown Kit is designed to be installed with a Lokar Cable Bracket (not included, available separately). The Lokar Kickdown Cable is designed to be cut-to-fit.

Refer to Figs. 1, 2 and 3 for the component names.

**Step 1:** Remove the cable end stop, kickdown throttle body fitting, and kickdown cable adjuster from the new Lokar Kickdown Cable. **DO NOT remove the ferrule from the cable housing if the cable housing is braided stainless steel.** Fig. 4 Leave the kickdown mounting bracket on the kickdown cable adjuster. Remove the inner wire from the cable housing.

**Step 2:** From the engine end of the kickdown cable housing, install the tube hold down clip onto the cable housing with the lip pointed downwards, and slide it down to the trans tube at the end of the cable housing. Temporarily install the cable housing into the transmission without the O-ring(s) and inner wire. **Note:** Some original kickdown cables used a top-hat style seal in the transmission. Verify there isn't a seal remaining in the kickdown cable hole in the transmission.

Loosely install the bolt for the tube hold down clip, to keep the cable housing from accidentally coming out of the transmission. Fig. 5

**Note:** TH200 and TH350 transmissions could have come with either a standard or a metric bolt for the trans tube hold down clip. For those applications, we have included both a standard 1/4"-20 and a metric M6 bolt and lock washer for the trans tube hold down clip. The standard 1/4"-20 bolt has a rounded button head, and the metric M6 bolt has a square-shouldered socket head. Fig. 2 The TH200-4R, 700-R4, and 4L60 will only have a metric bolt and washer in the kit.

# GM Hi-Tech Kickdown Kit Installation Instructions

For TH350, 700-R4, TH200, TH200-4R, and 4L60

Building American Quality... With A Lifetime Warranty!®

TOLL FREE 1-877-469-7440 • tech@lokar.com • www.lokar.com

**Step 3:** If the throttle cable has already been installed, disconnect the throttle cable from the throttle linkage arm. If the engine already has a Lokar Cable Bracket installed, remove the throttle cable adjuster. Leave the Cable Bracket in place. If the engine does not have a Lokar Cable Bracket already installed, install one now, following the installation instructions provided with the Lokar Cable Bracket (not included).

**Step 4:** The kickdown mounting bracket mounts onto the back side of the Lokar Cable Bracket. The throttle cable adjuster will pass through the top hole in both the new kickdown mounting bracket **AND** the Cable Bracket. Position the kickdown mounting bracket behind the Cable Bracket so the 5/16" diameter holes at the top of both brackets are aligned, the small 3/16" diameter holes near the center of the two brackets are aligned, and the kickdown cable adjuster is offset towards the driver side of the vehicle.

Attach the kickdown mounting bracket to the Cable Bracket using the supplied #8-32 x 1/2" button head bolt and nylock nut through the small 3/16" diameter center holes in both brackets, but do not tighten yet. Insert the throttle cable adjuster (with the rear nut still installed) from the rear through the top holes in both brackets. Position the throttle cable adjuster so the bracket is roughly centered in the threaded part of the cable adjuster. Install the front adjuster nut.

Tighten the throttle cable adjuster nuts, the button head bolt and nut, and the kickdown cable adjuster nuts. Fig. 6

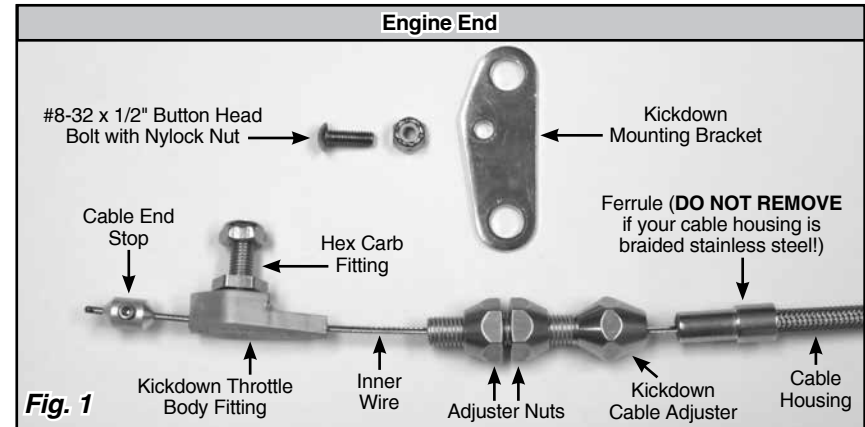

Fig. 1

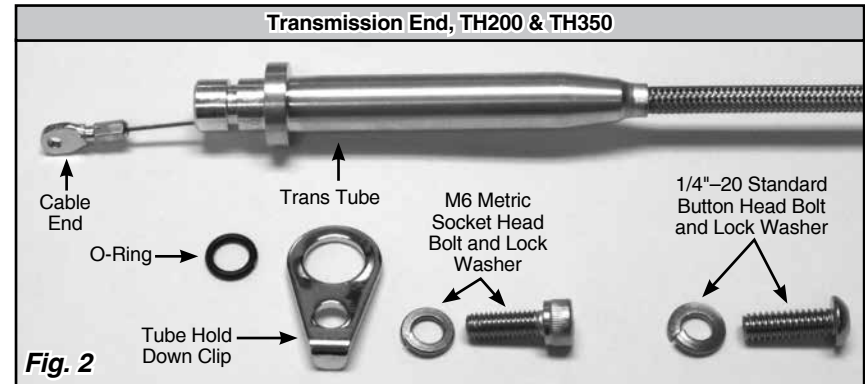

Fig. 2



Fig. 3

# GM Hi-Tech Kickdown Kit Installation Instructions For TH350, 700-R4, TH200, TH200-4R, and 4L60

**Step 5:** Route the cable housing up to the kickdown cable adjuster. **Make sure the inner wire is removed from the cable housing.** If the cable housing is braided stainless steel, slide the ferrule down the housing towards the transmission, away from the end being cut. **DO NOT remove the ferrule if your cable housing is braided stainless steel!** Fig. 4 If the cable housing is black universal or Vintage Series, remove the ferrule.

Measure the distance between the kickdown cable adjuster and the tube hold down clip. Add 1" to the measurement and cut the cable housing to that length.

If the cable housing is braided stainless steel, wrap tape around the area to be cut and use a cutoff wheel or fine-toothed hacksaw. If the cable has a black universal or Vintage Series housing, cut the cable housing with heavy duty 8" diagonal cutting pliers or a hacksaw. Lokar recommends Klein brand Diagonal Cutting Pliers, # D2000-28 available at The Home Depot or through W. W. Graingers, Part # 4A838.

After cutting the cable housing, put the ferrule back in place at the end of the cable housing. Insert the cable housing and ferrule into the kickdown cable adjuster. The ferrule does **NOT** need to be crimped or otherwise attached in place.

**Step 6:** The tear drop will be attached to the throttle arm by the hex carb fitting. Separate the hex carb fitting from the kickdown throttle body fitting. Install the hex carb fitting and the tear drop onto the throttle arm as shown in Fig. 7. Hook the springs to the tear drop and tighten the nylock nut on the hex carb fitting. Then, back the nylock nut off just enough so the tear drop can pivot freely.

**Step 7:** Remove the kickdown cable housing from the transmission. Re-install the inner wire into the kickdown cable housing.

**Step 8:** On the trans tube at the transmission end of the Kickdown Cable there will be either one or two O-ring grooves. TH350 & TH200 use one O-ring, and the 700-R4, TH200-4R, and 4L60 use two O-rings. Lightly lubricate the kickdown cable O-ring(s) with clean transmission fluid and slide the O-ring(s) into the groove(s) on the trans tube. To help prevent leakage add a small amount of silicone sealant (RTV) around the trans tube above the top O-ring. Fig. 5

**Step 9:** Insert the hook on the transmission kickdown rod into the hole in the cable end. Install the trans tube into the transmission, and secure with the tube hold down clip and bolt.

**Step 10:** Before connecting the Kickdown Cable to the throttle arm, install and adjust the throttle cable. Verify the throttle is wide open while you have a helper hold the accelerator pedal to the floor. Once you are sure the throttle linkage is adjusted correctly, slide the kickdown throttle body fitting onto the kickdown cable inner wire, and connect the kickdown throttle body fitting to the hex carb fitting.

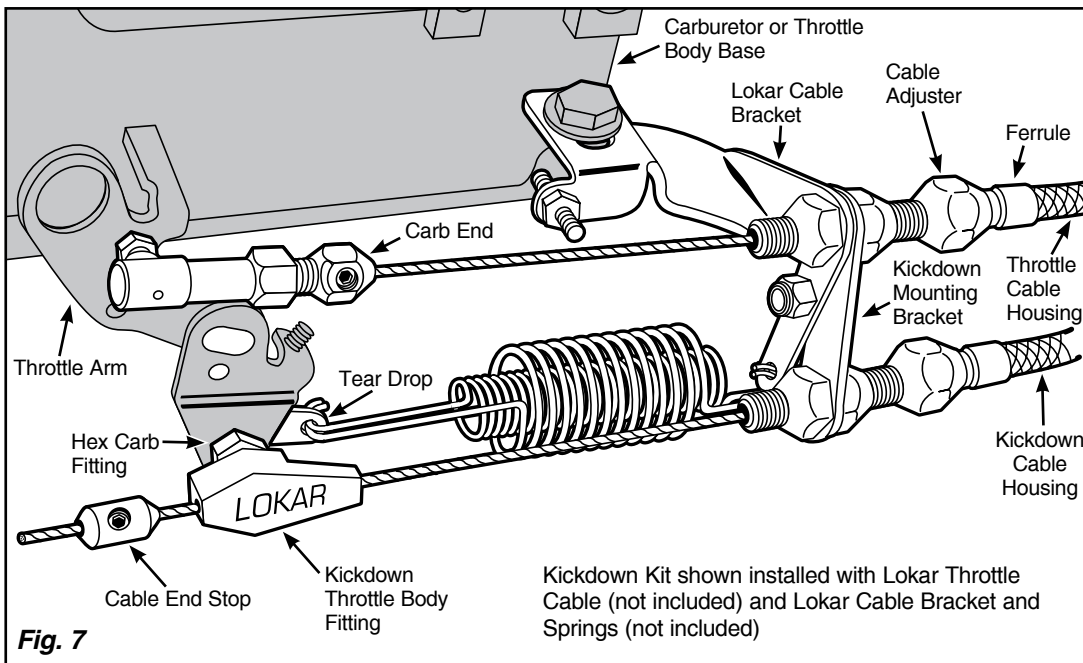
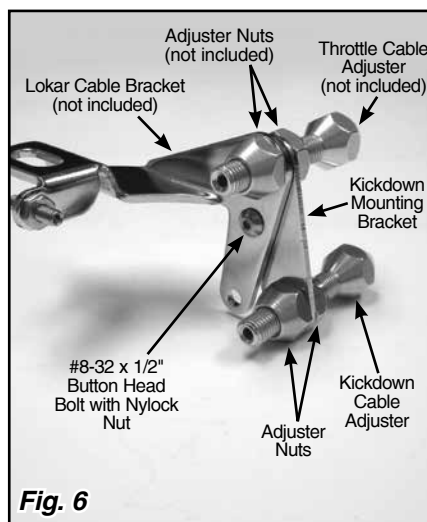
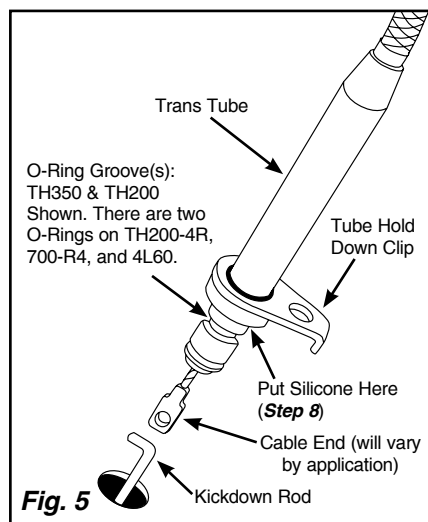
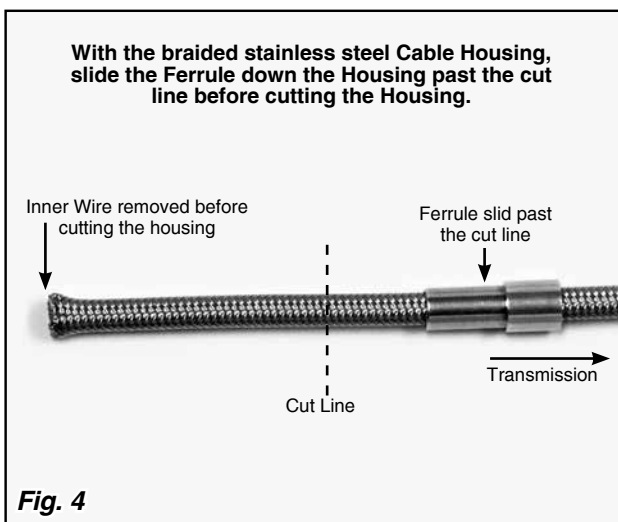

**Step 11:** This step will also be much easier with a helper. Slide the kickdown cable end stop onto the inner wire. Move the throttle to wide open and hold it there while pulling the kickdown inner wire as tight as possible. Slide the cable end stop up against the kickdown throttle body fitting and tighten the set screw using the supplied 5/64" Allen wrench. Release the throttle. When the Kickdown Cable is properly adjusted you should be able to open the throttle to the wide open position without interference from the Kickdown Cable; and with the throttle wide open, you should not be able to pull the Kickdown Cable out any further.

Double check to be sure all throttle and kickdown linkage operates freely without binding. Then, test drive the vehicle. Once the Kickdown Cable is correctly adjusted and operating properly you can cut off the excess inner wire, leaving about 1/2" extending beyond the cable end stop to allow for future adjustment if needed. Final installation should look like Fig. 7 and Fig. 8.