



QUALITY... PLAIN & SIMPLE®

GM Floor Mount Automatic Transmission Shifter Installation Instructions

General Installation Notes:

Please read these instructions completely before beginning the installation. If you have any questions, please call.

Before beginning the installation, disconnect the negative battery cable and use wheel chocks to block the vehicle's wheels.

Make sure the engine, transmission, body and frame are properly grounded.

All Lokar Installation Instructions can be found by visiting www.lokar.com/instructions.html.

Refer to Fig. 1 for the component names.

Tools and Materials Required:

- Standard Allen wrenches: 1/8", 5/32", 3/16"
- Wrench or Socket Sizes: 3/8", 7/16", 1/2", 9/16", 5/8", 7/8", 15/16", 13mm (metric transmissions only)
- Tape Measure
- Metal cutting tool, such as a hacksaw or a die grinder with a cut-off wheel
- Drill and 5/16" drill bit
- Ohmmeter
- Wire cutters/strippers
- Wire crimping or soldering tools
- Blue thread locking compound

Lokar Shifters are designed to fit specific transmissions. Before installation, verify you have the proper model for your transmission. If your Shifter does not seem to connect to the transmission properly, do not make modifications during installation as this may void your warranty. Call for assistance.

Verify the shifter length you have purchased is what you actually want. When installed, the bottom of the shifter lever will be approximately 3-1/2" - 4" above the bottom of the floor mount mounting bracket. From this point up to the top of the knob is how the shifter length is determined.

The Lokar Floor Mount Shifter is designed to be installed to the rear of the transmission selector shaft. If the Shifter will be located close to or in front of the transmission selector shaft, you will need a Shifter Cable Conversion Kit (available separately).

TH350, TH400 transmissions, Shifter Cable Conversion Kit # ATA-7001

700R4, 4L60, 200-4R transmissions, Shifter Cable Conversion Kit # ATA-7002

4L60E, 4L80E transmissions, Shifter Cable Conversion Kit # ATA-7006

The Shifter must be installed into the vehicle before attempting to make any adjustments.

GM Floor Mount Automatic Transmission Shifter Installation Instructions

Building American Quality... With A Lifetime Warranty!®

TOLL FREE 1-877-469-7440 • tech@lokar.com • www.lokar.com

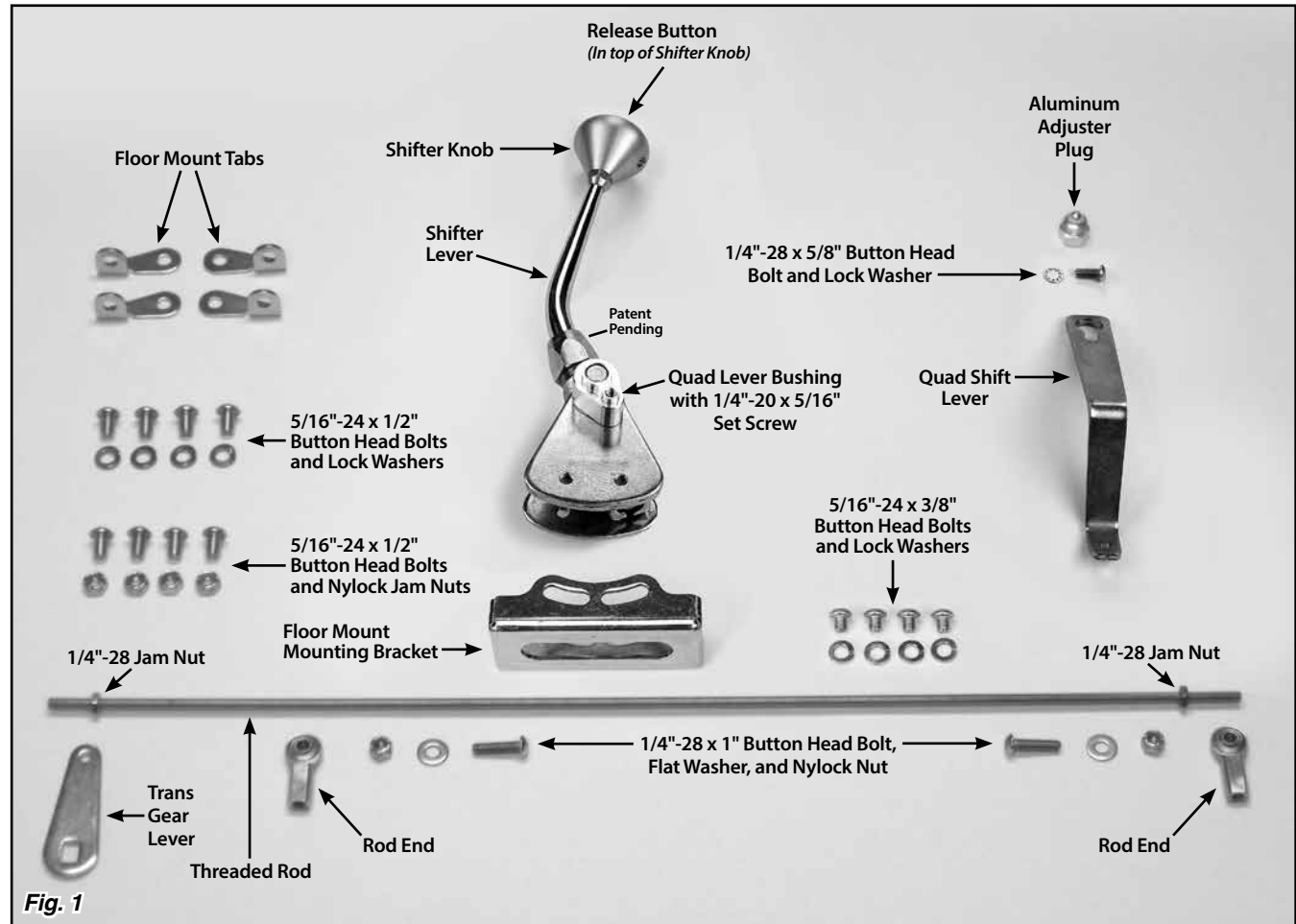

Fig. 1

The shifter lever is designed to lock in Park and in Neutral. You must depress the release button in the top of the shifter knob in order to shift out of Park or Neutral. The release button will only be flush with the top of the shifter knob when the shifter lever is in Park or Neutral.

To shift from Park directly to Drive (or Overdrive), depress the release button and hold it down while moving the shifter lever, and the shifter lever will stop in the Drive (or Overdrive) position. Once you release the button, the shifter lever will allow you to move into the next lower gear. You must depress the button to shift down again.

Step 1: If your vehicle already has a shifter of any type installed, disconnect all shifter linkage and remove the shifter and its related hardware (neutral safety switch, back-up light switch, etc.).

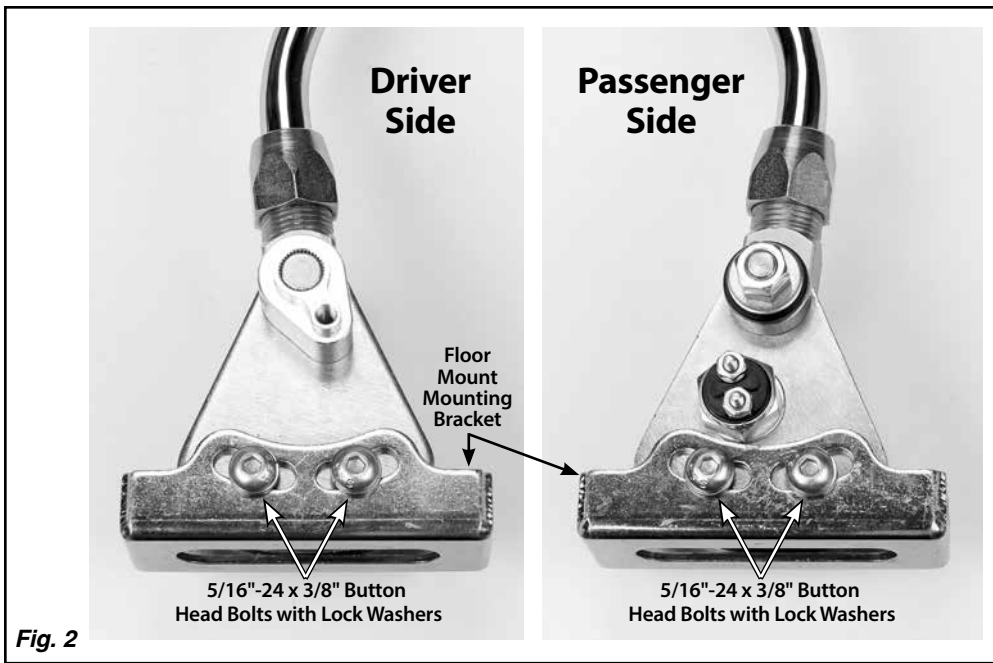

Fig. 2

Step 2: Take four 5/16" lock washers and the four 5/16"-24 x 3/8" button head bolts from the transmission shifter packet. **Make sure you are using 3/8" long bolts. They will be the shortest bolts in the packet.**

Place a lock washer on each of the bolts.

Position the shifter assembly into the floor mount mounting bracket as shown in **Fig. 2**. The floor mount mounting bracket can be installed in either direction (it does not have a front or a back). Install the 5/16"-24 x 3/8" button head bolts with lock washers through the curved, slotted holes and into the shifter assembly using a 3/16" Allen wrench. **Fig. 2**

Step 3: Determine exactly where you want the Shifter to be located. The Shifter may be mounted either on top of the floor or underneath the floor.

NOTE: For vehicles that had a floor shifter previously, determine if the existing hole(s) in the floor will be adequate for mounting and operation of the Lokar Shifter. If not, the floor will need to be modified.

If you are mounting the Shifter on top of the floor, you will need a slot in the floor for the quad shift lever to pass through. If you are mounting the Shifter underneath the floor, the opening will need to be large enough for the floor mount mounting bracket also.

NOTE: Round Lokar Shifter Boots and Boot Rings CANNOT be mounted directly on the floor with a Lokar Floor Mount Shifter.

The Shifter comes with a quad shift lever that has a 2-1/2" offset, which works the best in most installations. If the 2-1/2" offset will not work for your application, Lokar has quad shift levers available in both straight and 1-1/4" offset configurations. The bottom end of the quad shift lever should be generally aligned with the trans gear lever on the transmission. The quad shift lever does not need to be perfectly aligned with the trans gear lever. The rod ends allow for a certain amount of misalignment.

Step 4: There are two pairs of floor mount tabs in the Shifter Kit. Which pair goes where will depend on if you are mounting the Shifter above or below the floor. See **Fig. 3** to determine how the floor mount tabs need to be positioned for your particular application.

The floor mount tabs on the rear of the Shifter must be installed with the ears pointing towards the rear of the vehicle. If you are installing a rectangular Lokar Shifter Boot and Ring directly on the floor, the floor mount tabs on the front of the Shifter must also be installed pointing towards the rear of the vehicle. If you are not installing a rectangular Lokar Shifter Boot and Ring directly on the floor, you may install the front floor mount tabs facing either direction.

Attach the floor mount tabs to the floor mount mounting bracket as shown in **Fig. 3** with the provided 5/16"-24 x 1/2" button head bolts and lock washers. Leave the bolts loose enough so adjustments can be made later during the installation.

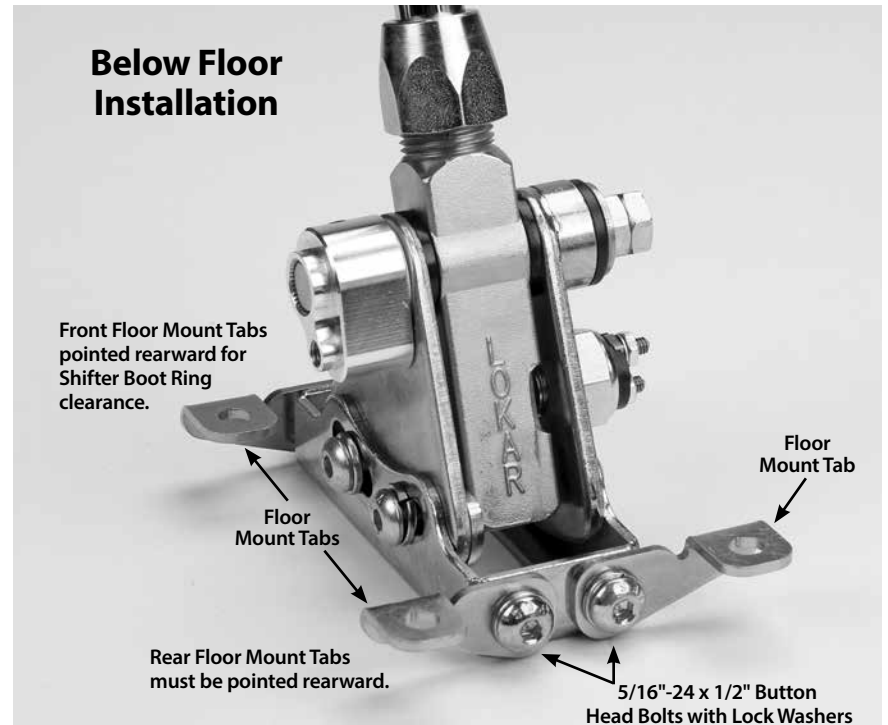
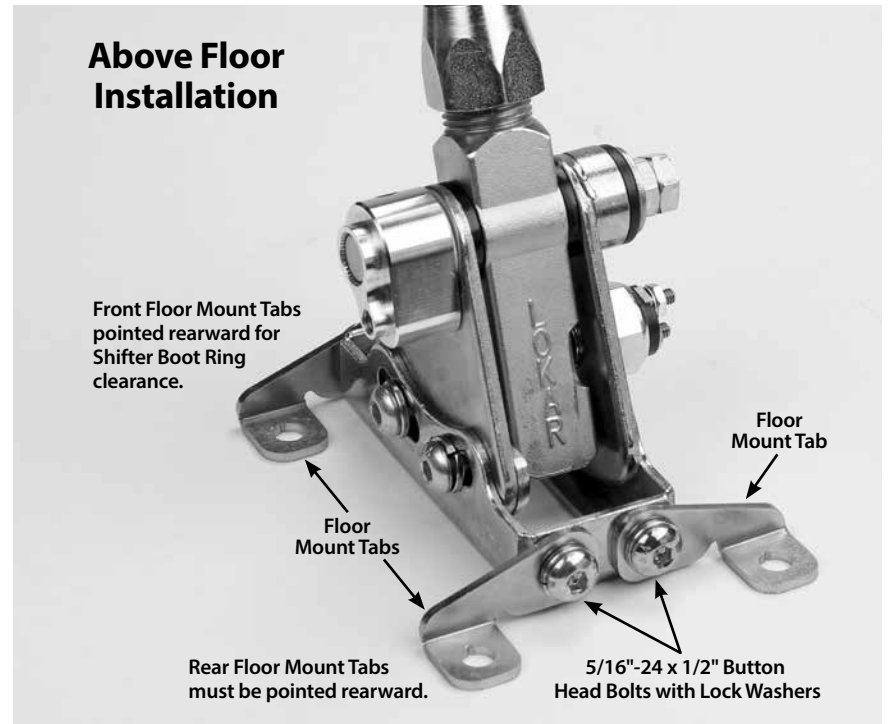

Fig. 3

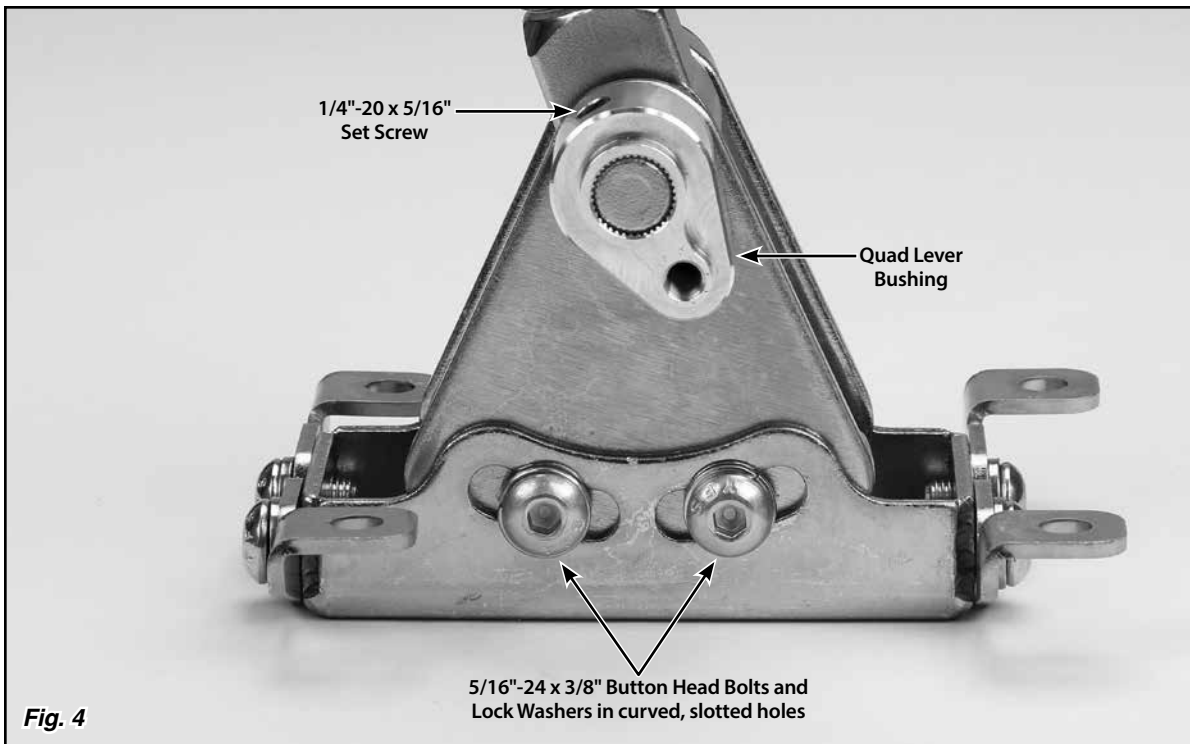

Fig. 4

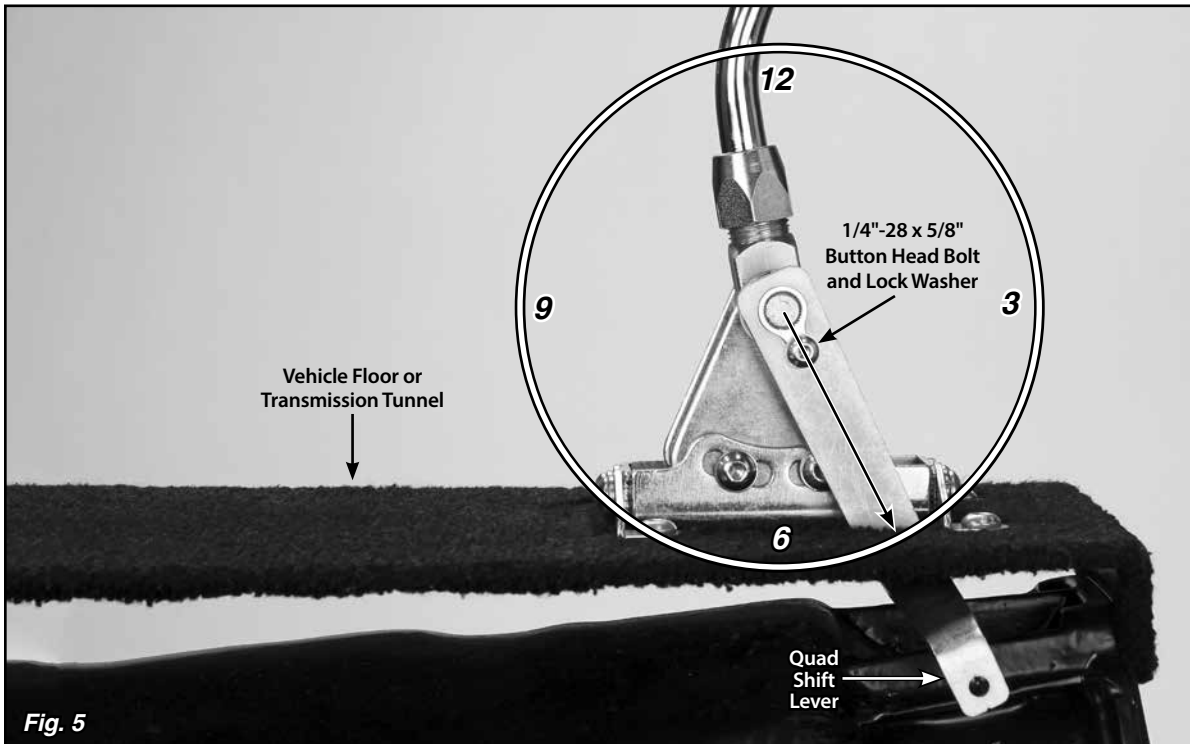

Fig. 5

Step 5: Make sure the two 5/16"-24 x 3/8" button head bolts and lock washers in the curved, slotted holes in the driver side of the floor mount mounting bracket are tight using a 3/16" Allen wrench. Place the Shifter in the desired location on the vehicle's floor. Make sure the shifter lever will not interfere with the dash when in Park, or with the seat when in low gear. The shifter assembly may be tilted forward or backward if needed by loosening the two 5/16"-24 x 3/8" button head bolts and lock washers in the curved, slotted holes in the driver side of the floor mount mounting bracket. Retighten the button head bolts and lock washers in the curved, slotted holes once you have the shifter assembly at the angle you want. **Fig. 4**

If you ever disassemble the shifter assembly, be sure the 5/16"-24 x 3/8" button head bolts and lock washers are put back into the curved, slotted holes in the floor mount mounting bracket. **Installing longer bolts will prevent the Shifter from operating.**

NOTE: If after installation you find the shape or length of the shifter lever is not suitable for your application, Lokar has a number of different styles and lengths of Shifter Lever Conversion Kits available for purchase separately through our dealer network.

Step 6: Determine the size and location of any openings that need to be cut in the floor in order to mount the shifter assembly and allow full travel of the quad shift lever. It may be useful to temporarily mount the quad shift lever to the quad lever bushing (see **Step 9**) and move the shifter lever through its full range of motion, in order to help determine where the cuts need to be made.

Cut those openings now.

Step 7: Place the shifter assembly in position on the vehicle. Push the floor mount tabs flush against the floor, and mark the center of the bolt holes in the floor mount tabs onto the floor. Center punch the marks, and drill four 5/16" diameter holes.

Step 8: Attach the floor mount tabs to the floor using four 5/16"-24 x 1/2" button head bolts and nylock jam nuts. Once the shifter assembly is mounted to the floor, tighten the floor mount tab to floor mount mounting bracket bolts using a 3/16" Allen wrench.

Step 9: Make sure the shifter lever is in the Park position. Temporarily place the quad shift lever in position on the quad lever bushing as shown in **Fig. 5**. Check for interference with the driver side rear floor mount tab or the vehicle floor. With the shifter lever in Park, you want the quad shift lever to be as close to the 4:30 - 5:00 position as the floor mount tab will allow, without the quad shift lever touching the floor mount tab or floor.

If the quad shift lever is not pointed towards the 4:30 - 5:00 position, loosen the set screw in the top of the quad lever bushing using a 1/8" Allen wrench. Slide the quad lever bushing off of the shifter. Reinstall the bushing pointed towards approximately the 4:30 - 5:00 position as shown. Retighten the set screw.

With the quad shift lever in position on the quad lever bushing, install the 1/4"-28 x 5/8" button head bolt and lock washer into the bushing, and tighten with a 5/32" Allen wrench.

Step 10: Make sure the transmission is in Park by rotating the original trans gear lever clockwise as far as it will go. Remove the original nut and trans gear lever from the transmission selector shaft. Install the new trans gear lever onto the selector shaft, pointed up and slightly towards the rear, at approximately the 1:00 position.

Secure the new trans gear lever with your original nut. **Fig. 6**

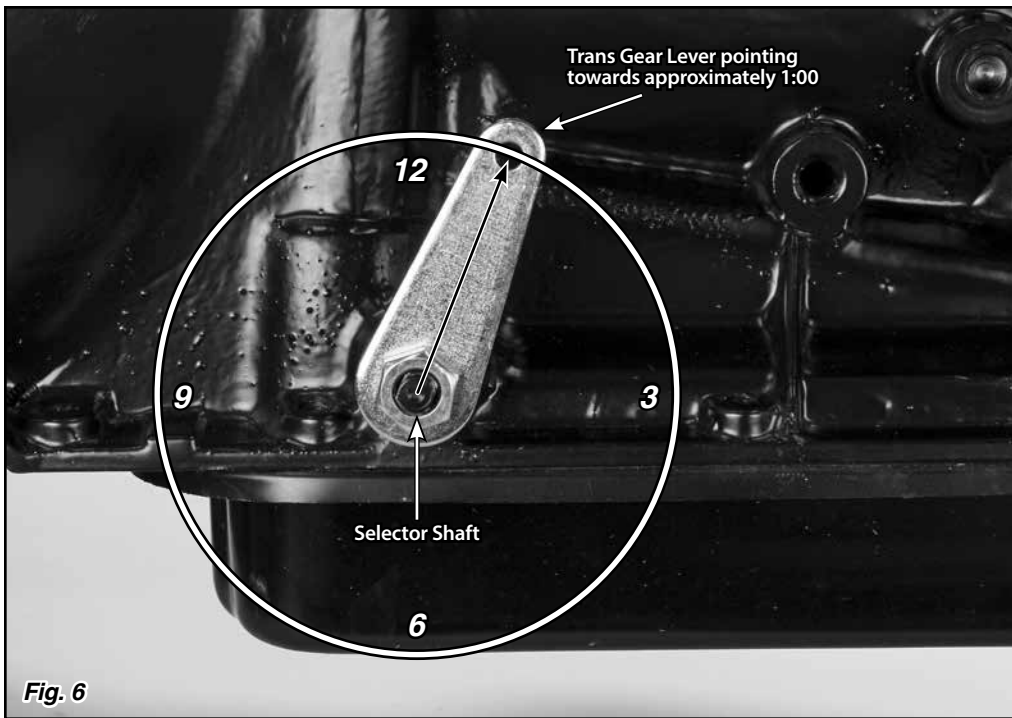

Fig. 6

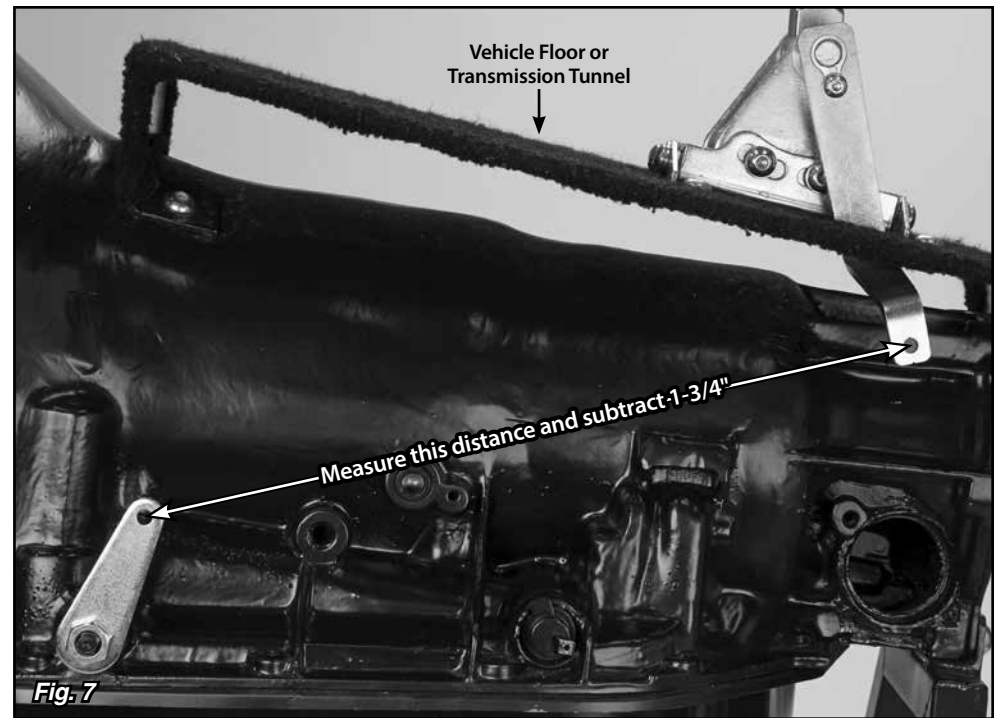

Fig. 7

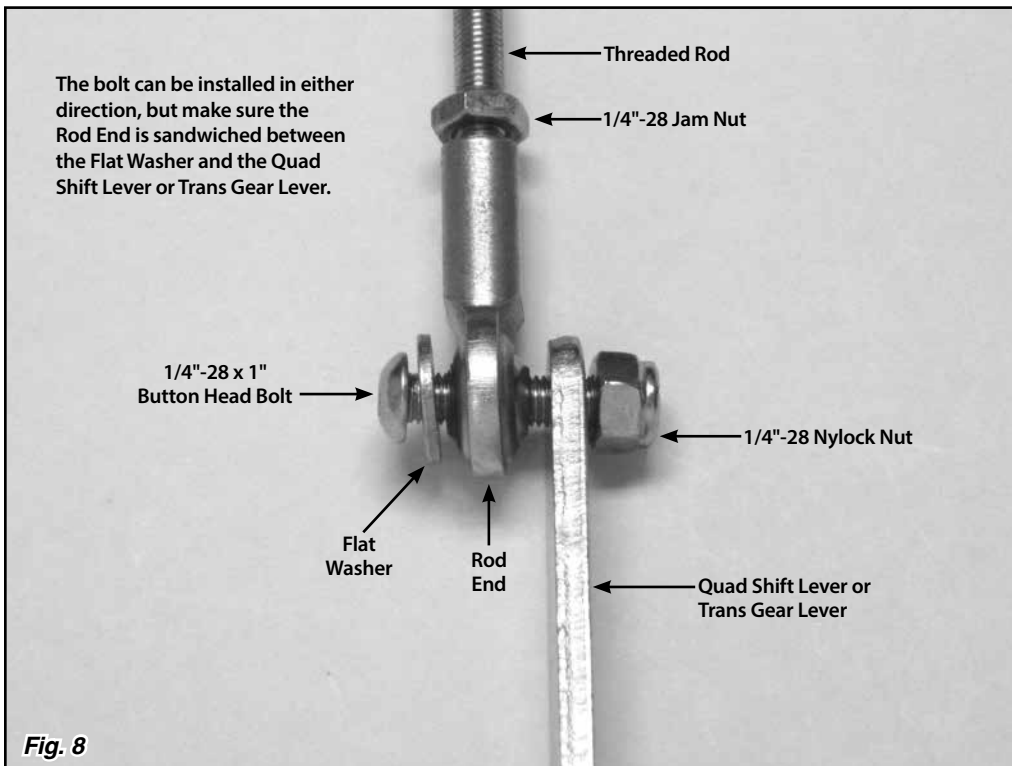

Fig. 8

Step 11: The threaded rod will connect the quad shift lever to the trans gear lever. Check to make sure nothing will interfere with the travel of the threaded rod. Some transmission cases have an external casting feature that may need to be trimmed slightly with a grinder to prevent interference with the threaded rod, depending on the location of your shifter.

If there is any interference, the threaded rod can be bent slightly as needed.

4L60E transmissions with a Manual Lever Position Sensor (MLPS) on the selector shaft will likely require an offset bend in the threaded rod in order to clear the sensor.

Verify both the shifter lever and the transmission are in the Park position. Measure center-to-center between the 1/4" holes in the trans gear lever on the transmission and the quad shift lever on the Shifter. Subtract 1-3/4". **Fig. 7** This is the length you will cut the threaded rod to. Use a hacksaw or cutoff wheel to shorten the threaded rod. Then, deburr the cut end.

Step 12: Make sure two 1/4"-28 jam nuts are installed on the threaded rod, one at each end. Install a rod end onto each end of the threaded rod. Position the rod ends on the inside or outside of the quad shift lever and trans gear lever so the threaded rod is as straight as possible. Attach the threaded rod assembly to the quad shift lever and trans gear lever using the 1/4"-28 x 1" button head bolts, flat washers, and nylock nuts as shown in **Fig. 8**. The button head bolts can be installed from either direction, but make sure the rod ends are sandwiched between the flat washers and the quad shifter lever or trans gear lever. **Fig. 9**

Step 13: Check the adjustment of the shifter linkage by placing the shifter lever all the way forward into the Park position. Make sure the release button still moves up and down freely. The release button should be flush with the knob in Park and Neutral. In the Reverse position, you cannot pull the lever back into Neutral without depressing the release button.

While the Shifter is in the Park position, make sure the transmission is firmly in the Park detent, with no tension on the threaded rod. You can verify this by removing the 1/4"-28 x 1" button head bolt with nylock nut that attaches the rod end to the quad shift lever or trans gear lever at either end of the threaded rod. Make sure the hole in the rod end exactly aligns with the hole in the quad shift lever or trans gear lever. The bolt should pass freely through both holes at the same time without binding. Do not force the holes to line up.

If the holes are not aligned, screw the rod end in or out just enough to be able to slide the bolt in and out without putting tension on the threaded rod. Make sure the quad shift lever and trans gear lever do not move during the adjustment procedure. Use this adjustment routine until the bolt will pass freely in and out of both the rod end and the quad shift lever or trans gear lever. Reinstall the 1/4"-28 nylock nut and the flat washer in its proper position onto the bolt, and tighten using a 5/32" Allen wrench.

Once you have the shifter linkage adjusted correctly, tighten the jam nuts on the threaded rod.

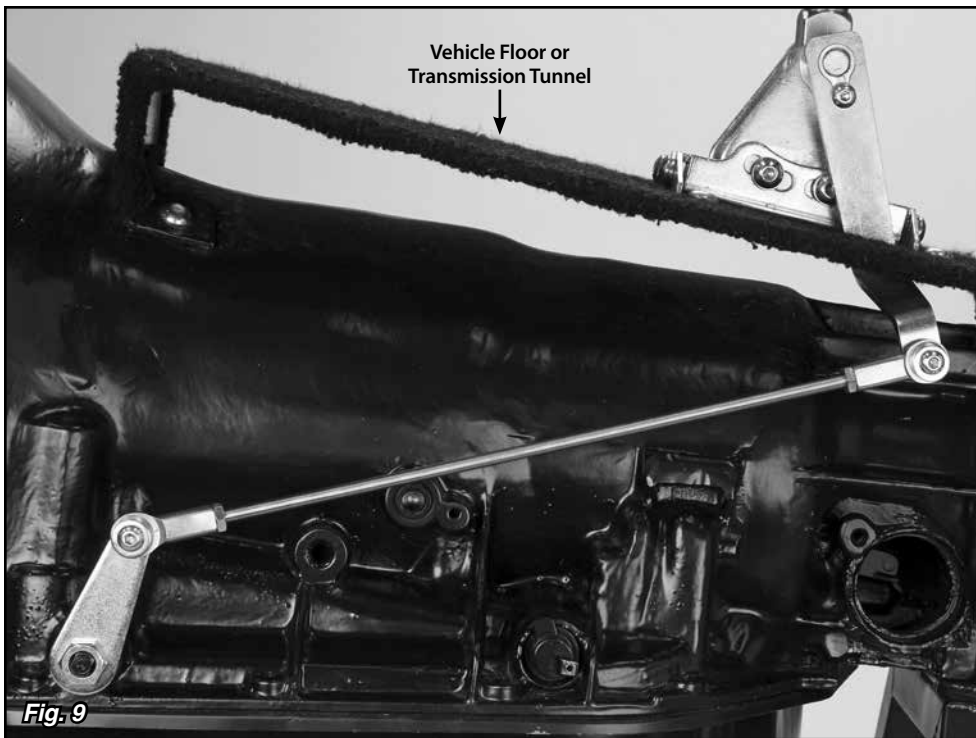

Fig. 9

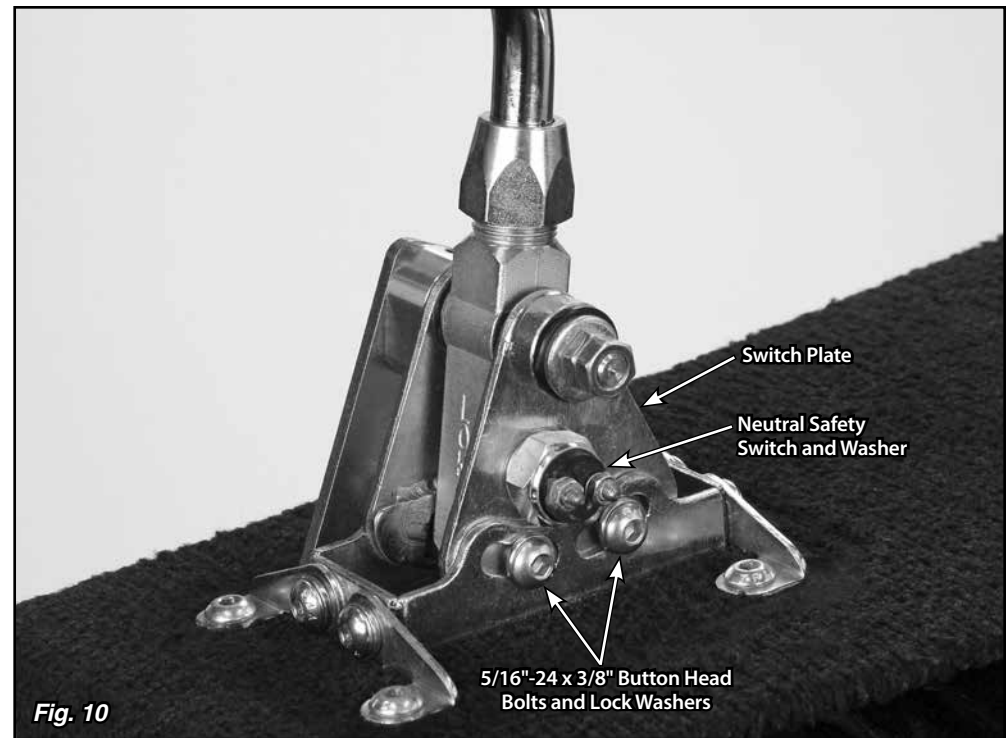

Fig. 10

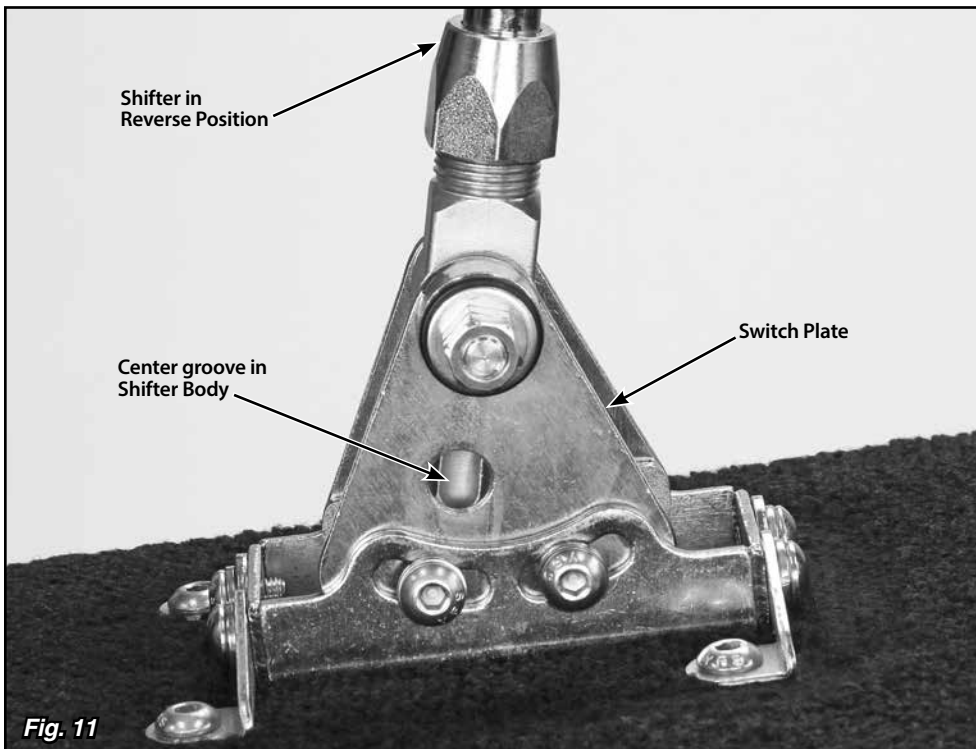

Fig. 11

Neutral Safety Switch Adjustment and Wiring

Step 14: For the neutral safety switch to function properly, the shifter linkage must be adjusted correctly. Do not attempt to adjust the neutral safety switch unless you have completed **Step 13**.

The Lokar neutral safety switch is a simple on/off, non-directional switch. The switch passes current (turns on) when the ball is pushed in. It does not pass current (turns off) when the ball is out at its at-rest position.

Double check to make sure the bolts in the curved, slotted holes on the driver side of the floor mount mounting bracket are tight.

Step 15: Remove the neutral safety switch and washer (**Fig. 10**) from the passenger side of the Shifter using a 7/8" wrench or socket.

Step 16: Loosen, but do not remove, the two 5/16"-24 x 3/8" button head bolts and lock washers that attach the passenger side of the floor mount mounting bracket to the switch plate (the bolts are in curved, slotted holes). **Fig. 10**

WARNING: Before taking the shifter lever out of Park, be sure the vehicle's tires are blocked and the parking brake is set to avoid movement of the vehicle.

Step 17: Put the shifter into the Reverse position. Reposition the switch plate so the hole in the switch plate lines up with the center groove in the shifter body. **Fig. 11** Screw the provided aluminum adjuster plug into the neutral safety switch opening. Moving the switch plate slightly forward and back while you are screwing the aluminum adjuster plug in will help get the shifter body centered on the adjuster plug. **Fig. 12**

Step 18: Retighten the two 5/16"-24 x 3/8" button head bolts and lock washers that attach the passenger side of the floor mount mounting bracket to the switch plate.

Step 19: Remove the aluminum adjuster plug, and reinstall the neutral safety switch and washer onto the shifter. Test for continuity by connecting an ohmmeter lead to each stud on the neutral safety switch. When adjusted correctly, you will only have continuity between the two switch studs when the shifter is in Park or Neutral. Continuity in any other gear requires readjustment of the neutral safety switch or the shifter linkage.

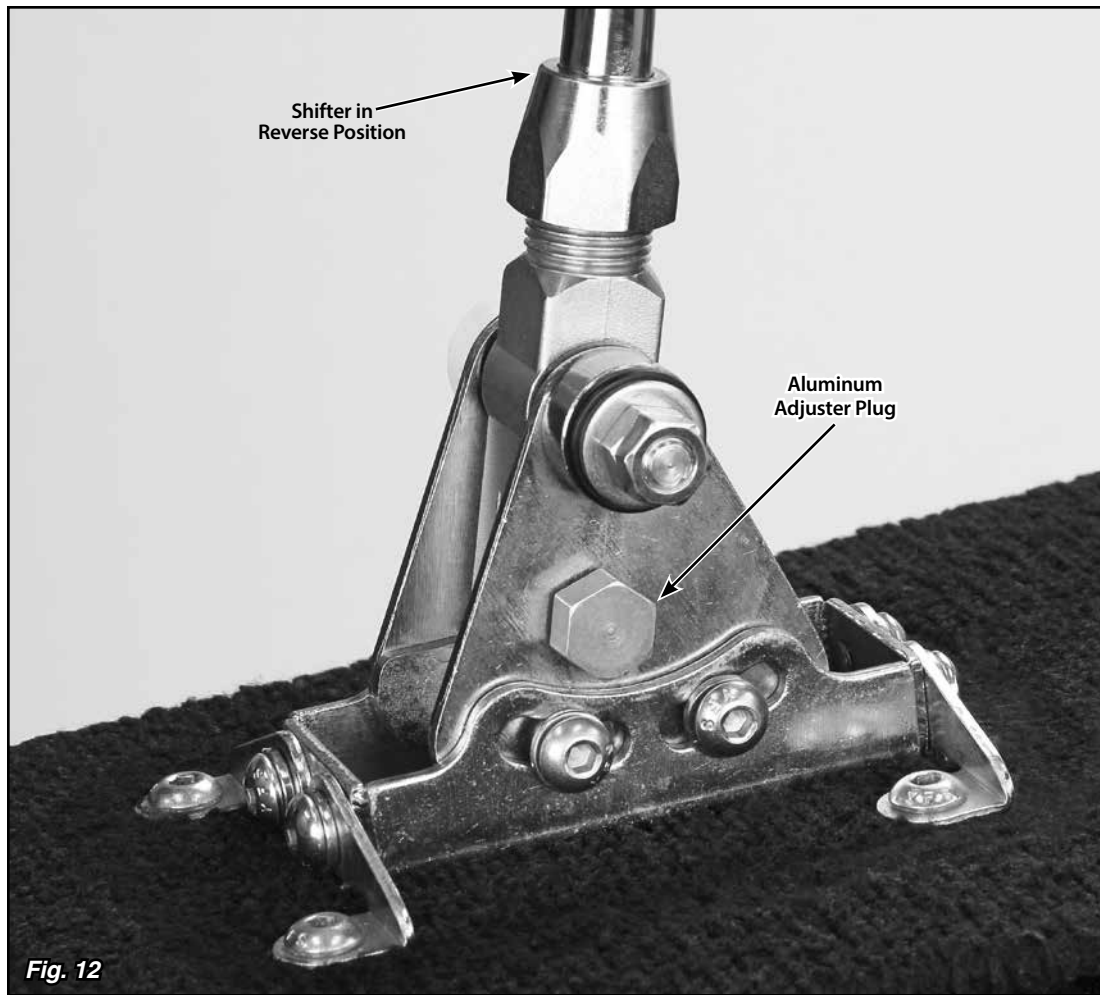

Fig. 12

Step 20: Connect the neutral safety switch between your ignition switch and starter circuits. Check the wiring of your fuse panel:

- **If there are (2) connections for a neutral safety switch**, route a #12 (or heavier) stranded wire from these terminals in your fuse panel to the (2) terminals on the neutral safety switch. That completes the neutral safety switch wiring.
- **If your fuse panel does not have neutral safety switch connections**, locate the wire going from the ignition switch to the starter. If GM color codes are used, this wire will usually be purple. After locating the wire, disconnect it from the starter. It must be cut and routed from the ignition switch to one of the neutral safety switch terminals, and from the other neutral safety switch terminal to the same stud on the starter where the original wire was removed. If the wire must be lengthened, be sure to use wire at least the same size or larger than the original.

Step 21: Reconnect the negative battery cable and check operation. Make sure the engine will not start in reverse or a drive gear. If it does, follow the neutral safety switch adjustment procedure again. ***If your car should ever start in any gear other than Park or Neutral, please readjust the neutral safety switch.*** Tighten all brackets and bolts correctly and securely and there should be no movement or maladjustment. If you have any questions after following this procedure, please call Lokar Technical Support.

Step 22: Once the installation is completely finished and the neutral safety switch is adjusted, remove each of the 5/16"-24 x 3/8" button head bolts and lock washers from the curved, slotted holes in the floor mount mounting bracket one at a time, apply blue thread locking compound to the threads, and reinstall.

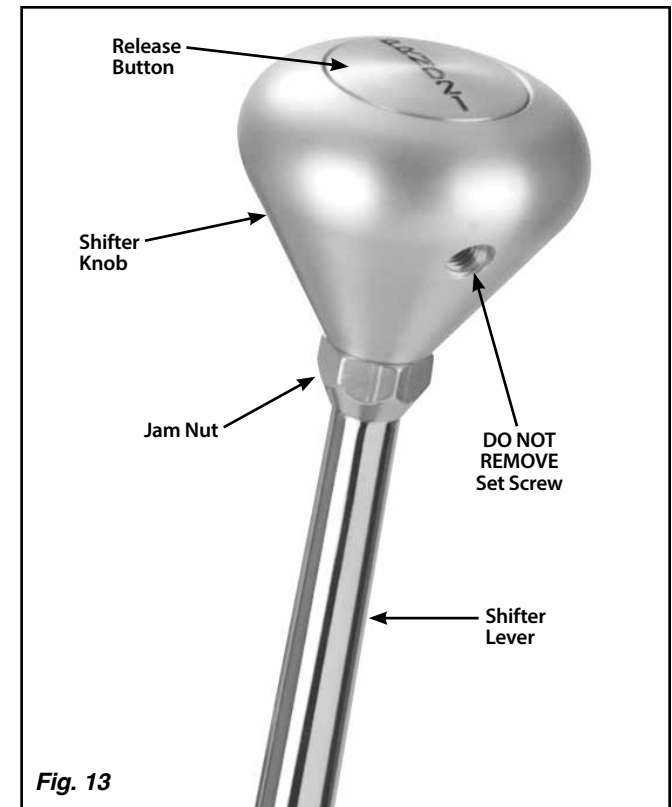

Fig. 13

Lokar Shifter Knob Removal Instructions (For Shifters Manufactured 1995 and Later)

For Shifters manufactured 1994 and earlier, please contact Lokar for assistance.

To Remove the Shifter Knob:

- Step 1:** Make sure the Shifter is all the way forward in the Park position.
- Step 2:** Loosen the jam nut below the shifter knob. **DO NOT** loosen or remove the set screw in the knob. **Fig. 13**
- Step 3:** Turn the shifter knob counter-clockwise to remove.

To Install the Shifter Knob:

- Step 1:** Make sure the jam nut is still in place on the shifter lever.
- Step 2:** Screw the shifter knob onto the shifter lever until the release button comes up flush with the top of the shifter knob.
- Step 3:** Tighten the jam nut up against the bottom of the shifter knob.
- Step 4:** Check to make sure depressing the release button allows the shifter lever to be moved and the shifter lever still locks in Park and Neutral. If the Shifter will not come out of Park with the release button fully depressed, tighten the knob one turn and check it again. If the Shifter does not lock in Park, loosen the knob one turn and check it again.